

ARS

Australian Riveting Supplies
Product Catalogue

Rivets
Bolts
Drill Bits
Silicones
Fasteners
Abrasives
Self Drilling Screws
Safety Products
Huck Fastening



September 2018



TABLE OF CONTENTS

RIVETS

Page 1. Multigrip	5. Steel	9. Closed End
2. Aluminium/Steel	6. All Stainless Steel	10. Blister Packs
3. Coloured	7. Nickel Copper Alloy	
4. Aluminium L/F, Csk	8. All Aluminium, Peeled	

STRUCTURAL FASTENERS

11-12. Huck Magna-Lok	16. Huck-Lok	19. Huck Tool Selection
13-14. Huck Magna-Grip Pins	17-18. Huck Magna-Bulb	20. Panelok
15. Huck Tooling	18. Hucktainer	21. Bulb-Tite

THREADED INSERTS

22. Steel L/F, Stainless Steel	23. Flush Mount Steel	24. Plusnut & Jacknut
22. Aluminium L/F	23. Flush Mount Stainless Steel	25. Threaded Insert Tools
	23. Hex Large Flange	

RIVET TOOLS

26-28. Hand Rivet Tools
29-30. Air Pneumatic Rivet Tools
31-32. Battery Rivet Tools

MASONRY ANCHORS

33. Sleeve Anchors	37. Hollow Wall & Metal Pin Anchors	41-43. Power Actuated Tools Pins & Charges.
34. Thru Bolts & Studs	38. Wallmates & Nylon Anchors	
35. Drop in Anchors	39. PVC Wall Plugs	
36. Thunder Bolt Anchors	40. Framing Nails	

SELF DRILLING SCREWS

44. Roofzips & Ripplezips	48. Flat top, Button Hd, Wing Tek, Decking	52. Bugle Needle Point
45. Hex Self Drill Metal	49. Steel House Framing Screws	52. Chipboard
46. Series 500 & Skylight Screws	50. Type17 Timber Hex, Bugle Battens	53. Particle Board & Superchip
47. Csk, Pan, Wafer & Bugle	51. Type17 Csk, Wafer, Pan, Treated Pine	53. Adhesive Caps

SELF TAPPING SCREWS

54. Pan & Csk Z/P	56. Quik Drive Products
55. Pan & Csk 304 Stainless Steel	

STAPLES

57. Staples, Brads,

DRILL BITS

58. Jobber Drills	63. Masonry Drills & snappy Bits	68. Step Drills
59. Panel Drills & Cobalt Drills	64. SDS Masonry Drills	69. Cylindrical Burrs
60. Drill Sets	65. Auger & Spade Bits	69. Screw Extractors
61. Drills Titanium Coated	66. Longseries Drills	70-71. Taps & Dies
62. Reduced Shank drills	67. Holesaws	

ABRASIVE PRODUCTS

72. Cut Off & Grinding Wheels	75. Sandpaper Rolls & Sheets
73. Fibre Disc	75. Industrial Wire Brushes
74. Flap Disc & Sanding Belts	76. Diamond Saw Blades & Hand Files

BOLT PRODUCTS

77-78. Mild Steel Grade 4.6 Bolts	82. Metal Thread Screws	87. Threaded Rod
79. High Tensile Grade 8.8 Bolts	83. Roof Bolts & Tee Nuts	
80. Structural Assemblies	84. Nuts - Hex, Nyloc, Dome & Wing	
81. Cup Head Bolts	85-86. Stainless Steel Bolts	



TABLE OF CONTENTS

WASHERS

- | | |
|-----------------------------|------------------------------------|
| Page 88. Flat Round Washers | 90. Lock Washers |
| 89. Spring Washers | 90. Red Fibre, Nylon & Cup Washers |
| 89. High Tensile Washers | |

SCREW DRIVER BITS

- | | | |
|--------------------------|------------------------|---------------------------|
| 91. Phillips Tips | 93. Torx & Hex Bits | 95. Pozi Bits |
| 92. Impact Driver Bits | 94. Square Driver Bits | 95. Screw Driver Bit Sets |
| 92. Slot & Maxdrive Bits | 94. Magnetic Sockets | |

AIR FITTINGS AND JIGSAW BLADES

- | | |
|-------------------|-----------------------------|
| 96. Air Fittings | 98. Sabre Saw Blades |
| 97. Jigsaw Blades | 98. Hacksaw Blades & Frames |

SILICONES

- | | | |
|---------------------------------|--------------------------------------|-------------------|
| 99. Plumbers Silicone | 101. Gapseal, Infinity FC MS Polymer | 104 Caulking Guns |
| 100. Sanitary Grade Silicone | 102. Sika Product | |
| 101. No Nails & coolroom Mastic | 103. Bostik Product | |

PIPE FLASHINGS

- | | |
|---------------------------|---------------------------|
| 105. Pipe Flashings | |
| 106 Expansion Strip Joint | 107. Tekkit Touch up Pens |

PACKERS

108. Packers & Shims

HARDWARE PRODUCTS

- | | | |
|----------------------------|----------------------------------|------------------------------------|
| 109. Touch up Spray Cans | 115. Spanners & Sockets | 121. Loctite & Instant Glue |
| 110. Wiss Snips & Seamers | 116. Hammers & mallets | 122. Tapes |
| 111. Midwest Snips | 117. Cable Ties | 123. Engineers Chalk & Cotter Pins |
| 112. Screw Drivers & Sets | 118. Utility Knives | 124. Lubricants |
| 113. Hand Pliers | 119. Rules, Levels & Chalk Lines | 125. Hand Cleaners & Rags |
| 114. Wire Cutters & Clamps | 120 Tape Measures | 126. Paint Brushes & Rollers |

HINGES

- | | | |
|---------------------------|----------------------------------|------------------------|
| 127. Butt Hinges | 129. Pad Bolts & Door Knobs Sets | 130. Ratchet Tie Downs |
| 128. Gate Hinges & Laches | 130. Angle Brackets | |

SAFETY PRODUCTS

- | | | |
|---------------------|-------------------------|-----------------------------|
| 131. Gloves General | 134. Hearing Protection | 135. Knee & Back Protection |
| 132. Gloves Welders | 134. Dust Masks | 136. Site Safety |
| 133. Eye Protection | 135. Safety Vest | |
-



TERMS & CONDITIONS OF SALE

1. PAYMENT TERMS

Are strictly nett and are payable on or before the last day of the month following the month of despatch unless otherwise agreed in writing.

2. PRICES

The schedule herein is a guide only, there is no obligation to adhere to these prices.
Prices are subject to alteration without notice.
Prices exclude Gst

3. REQUEST FOR CREDIT

Return of goods are subject to company approval and are subject to a 15% restocking fee.
Broken packages will not be accepted.
All claims for any reason must be made within 7 days from date of delivery.

4. LIABILITY

No warranty shall be given or implied that goods supplied are suitable for the buyers purpose unless such purpose has been specified and agreed in writing, nor shall the company be liable for any damage resulting from unsuitability for any purpose nor for any loss resulting from third party claims.

5. RETENTION OF TITLE

Title to the products purchased by the buyer from Australian Riveting Supplies will pass to the buyer only when all monies owing to Australian Riveting Supplies in relation to products ordered by and delivered to the buyer have been paid in full.
Australian Riveting Supplies may take possession of, and sell, any unpaid products in the event the buyer defaults or becomes insolvent.

6. ORDER VALUE/DELIVERIES

A freight fee will be charged for orders under \$400.00 Net Value.



MULTIGRIP RIVETS

DOME HEAD - ALUMINIUM RIVET, STEEL MANDREL

Material: Body: Aluminium Alloy 5052

Mandrel: Carbon Steel

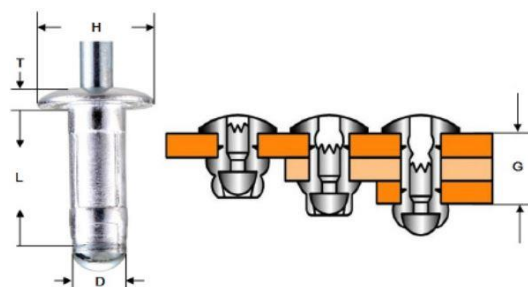

One rivet can be used in multiple material thickness, this reduces inventories and eliminates operator error.

Stem is locked in shell, eliminating the risk of mandrel head vibrating loose while providing a weather resistant joint.

The bulbing formation of the multi-grip rivet will fill slightly oversized holes, providing increased strength and vibration resistance.

RIVET CODE			RIVET DIA D		DRILL SIZE	RIVET L LENGTH MAX MM	GRIP RANGE G	STANDARD STRENGTH N. (nom.)		HEAD DIAMETER H (mm)	HEAD THICKNESS T (mm)Max	BULK QTY	BOX QTY
			INCH	MM				SHEAR	TENSILE				
ALUMINIUM DOME HEAD RIVETS													
ASMG43			1/8	3.2	#30 3.3	8.2	1.0 - 4.8mm	700N	1000N	6.4mm	1.20	20000	1000
ASMG45						11.4	3.2 - 8.0mm					10000	1000
ASMG46						13.0	4.8 - 9.6mm					10000	1000
ASMG54			5/32	4.0	#20 4.1	10.5	1.6 - 6.4mm	1000N	1600N	7.9mm	1.50	10000	1000
ASMG56						13.6	4.8 - 9.6mm					10000	500
ASMG63			3/16	4.8	#11 4.9	11.1	1.6 - 6.4mm	1300N	2100N	9.5mm	1.60	5000	500
ASMG67						15.9	6.4 - 11.2mm					5000	500
ASMG69						19.3	9.6 - 14.3mm					5000	500
ASMG612						23.8	14.3 - 19.1mm					5000	250
ASMG614						27.0	17.6 - 22.3mm					2500	250
ALUMINIUM LARGE FLANGE RIVETS													
ASMG68LF			3/16	4.8	#11 4.9	17.5	8.0 - 12.7mm	1300N	2100N	16.0mm	2.34	2500	250
ASMG612LF						23.8	11.2 - 19.1mm					2000	200
ALUMINIUM COUNTERSUNK RIVETS													
ASMG64CSK			3/16	4.8	#11 4.9	11.1	1.6 - 6.4mm	1300N	2100N			5000	500
ASMG67CSK						15.9	6.4 - 11.2mm					5000	500
ALUMINIUM DOME HEAD RIVETS WITH 304 STAINLESS STEEL STEMS													
ASTMG53-55			5/32	4.0	#20 4.1	12.0	1.6 - 6.4mm	1000N	1600N			5000	500
ASTMG53-55SU			Painted shell Surfmist									5000	500
STAINLESS STEEL 304 DOME HEAD RIVETS WITH STAINLESS STEEL STEMS													
STSSMG41-43			1/8	3.2	#30 3.3	9.9	1.0 - 4.8mm	1440N	1980N	6.4mm	1.20	20000	1000
STSSMG44-46						14.6	4.8 - 9.6mm					10000	1000
STSSMG52-54			5/32	4.0	#20 4.1	12.0	1.6 - 6.4mm	2420N	3250N	7.9mm	1.50	10000	1000
STSSMG54-56						15.2	4.8 - 9.6mm					10000	500
STSSMG62-63			3/16	4.8	#11 4.9	11.1	1.6 - 6.4mm	4000N	4490N	9.5mm	1.60	5000	500
STSSMG64-66						15.9	4.8 - 9.6mm					5000	500
STSSMG66-68						19.3	8.0-12.7mm					5000	500
STSSMG69-611						23.8	12.7-17.5mm					5000	250

PRICES \$ PER 1000 BULK AND BOX PACKS



ALUMINIUM RIVETS AS

DOME HEAD - ALUMINIUM RIVET, STEEL MANDREL

Material: Body: Aluminium Alloy 5050

Mandrel: Carbon Steel

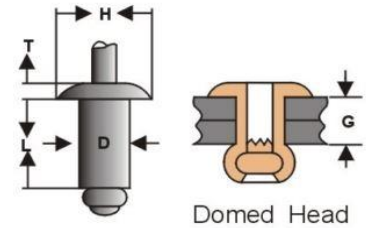

Domed Head

A general purpose rivet used extensively for:-

Roofing, guttering, flyscreen doors, toys, white goods, garden sheds, roller doors, caravans, boats,

Electrical appliances, building industry. Can be used as exterior/interior rivet.

RIVET CODE			RIVET DIA D		DRILL SIZE	RIVET L LENGTH MAX MM	GRIP RANGE G	STANDARD STRENGTH		HEAD DIAMETER H (mm)	HEAD THICKNESS T (mm)Max	BULK QTY	BOX QTY
			INCH	MM				LBS (min)	TENSILE				
AS3-3			3/32	2.4	2.5	8.0	3.2 - 4.8	70	80	4.3 - 5.0	0.8	20000	1000
AS4-1			1/8	3.2	#30 3.3	5.1	0.8 - 1.6	120	150	5.8 - 6.5	1.2	20000	1000
AS4-2						6.7	1.6 - 3.2					20000	1000
AS4-3						8.2	3.2 - 4.8					20000	1000
AS4-4						9.9	4.8 - 6.4					20000	1000
AS4-5						11.4	6.4 - 7.9					20000	1000
AS4-6						13.0	7.9 - 9.5					20000	1000
AS4-8						16.2	9.5 - 12.7					10000	1000
AS4-10						19.4	12.7 - 15.9					10000	1000
AS4-12						22.2	15.9 - 19.0					10000	500
AS5-2			5/32	4.0	#20 4.1	7.3	1.6 - 3.2	190	230	7.0 - 8.0	1.5	10000	1000
AS5-3						8.9	3.2 - 4.8					10000	1000
AS5-4						10.5	4.8 - 6.4					10000	1000
AS5-5						12.0	6.4 - 7.9					10000	1000
AS5-6						13.6	7.9 - 9.5					10000	1000
AS5-8						16.8	9.5 - 12.7					10000	500
AS5-10						20.0	12.7 - 15.9					10000	500
AS5-12						22.5	15.9 - 19.0					5000	500
AS6-2			3/16	4.8	#11 4.9	8.0	1.6 - 3.2	260	320	8.5 - 9.5	1.6	10000	500
AS6-3						9.5	3.2 - 4.8					10000	500
AS6-4						11.1	4.8 - 6.4					10000	500
AS6-5						12.7	6.4 - 7.9					10000	500
AS6-6						14.3	7.9 - 9.5					5000	500
AS6-8						17.5	11.1 - 12.7					5000	500
AS6-10						20.7	12.7 - 15.9					5000	250
AS6-12						23.8	15.9 - 19.0					5000	250
AS6-14						27.0	19.0 - 22.2					2500	250
AS6-16						30.2	22.2 - 25.4					2500	250
AS6-20						36.5	25.4 - 31.7					1500	150
AS6-22						40.0	30.0 - 35.0					1500	150
AS8-4			1/4	6.4	6.5	12.4	3.2 - 6.4	460	560	11.5 - 13.0	2.2	4000	400
AS8-6						15.5	6.4 - 9.5					3500	350
AS8-8						18.7	9.5 - 12.7					3000	300
AS8-10						21.9	12.7 - 15.9					2500	250
AS8-12						25.1	15.9 - 19.0					2500	250
AS8-16						31.4	22.2 - 25.4					2000	200

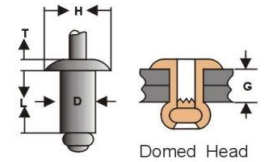

PAINTED RIVETS

DOMED HEAD - ALUMINIUM RIVET, STEEL MANDREL

RIVET CODE	RIVET DIA D INCH MM	DRILL SIZE	RIVET L LENGTH MAX MM	GRIP RANGE G	STANDARD STRENGTH		HEAD DIAMETER H (mm)	HEAD THICKNESS T (mm)Max	BULK QTY	BOX QTY
					LBS (min)	SHEAR TENSILE				
AS4-3	1/8 3.2	#30 3.3	8.2	3.2 - 4.8	120	150	5.8 - 6.5	1.2	20000	1000
AS4-4			9.9	4.8 - 6.4					20000	1000
AS4-6			13.0	7.9 - 9.5					20000	1000
ASMG56	5/32 4.0	4.2	13.6	4.8 - 9.6	225	360	7.9	1.27	10000	500
ASMG63	3/16 4.8	4.9	11.1	1.6 - 6.4	292	472	9.5	1.60	5000	500
ASMG67			15.9	6.4 - 11.2					5000	500

COLOUR NAME	AS4-3	AS4-4	AS4-6	ASMG56	ASMG63	ASMG67
Basalt™	X			X		
Bronze	X	X				
Classic Cream™	X		X	X		
Cottage Green™	X			X		
Cove™	X			X		
Deep Ocean™	X			X		
Dune®	X			X		
Evening Haze®	X			X		
Gully™	X			X		
Ironstone™	X			X		
Jasper™	X			X		
Manor Red™	X			X		
Mangrove™	X			X		
Monument™	X			X		
Night Sky™	X	X	X	X		X
Pale Eucalypt™	X			X	X	
Paperbark™	X	X	X	X	X	
Pearl White	X					
Shale Grey™	X			X		
Surfmist®	X			X	X	X
Terrain™	X			X		
White	X	X	X	X		X
Wallaby™	X			X		
Windspray®	X			X		
Woodland Grey™	X		X	X		

PRICES \$ PER 1000 BULK AND BOX PACKS



ALUMINIUM RIVETS LARGE FLANGE AS-LF DOME HEAD - ALUMINIUM RIVET, STEEL MANDREL

Material: Body: Aluminium Alloy 5050

Mandrel: Carbon Steel

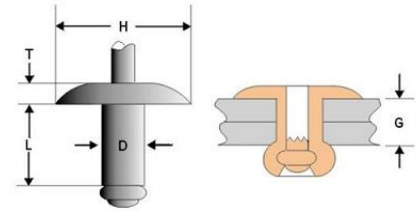

LARGE FLANGE RIVETS provide greater bearing surface for fastening soft and brittle facing materials such as plywood and plastics including neoprene, vinyl, etc.

RIVET CODE	RIVET DIA D INCH MM	DRILL SIZE	RIVET L LENGTH MAX MM	GRIP RANGE G	STANDARD STRENGTH		HEAD DIAMETER H (mm)	HEAD THICKNESS T (mm)	BULK QTY	BOX QTY
					LBS (min) SHEAR	TENSILE				
AS4-2LF	1/8 3.2	#30 3.3	6.7	1.6 - 3.2	120	150	9.6	1.6	10000	1000
AS4-4LF			9.9	4.8 - 6.4					10000	1000
AS4-6LF			13.0	7.9 - 9.5					10000	500
AS5-4LF	5/32 4.0	#20 4.1	10.5	4.8 - 6.4	190	230	12.0	1.9	5000	500
AS5-6LF			13.6	6.4 - 9.5					5000	500
AS6-3LF	3/16 4.8	#11 4.9	9.5	3.2 - 4.8	260	320	16.0	2.3	5000	250
AS6-4LF			11.1	4.8 - 6.4					5000	250
AS6-6LF			14.3	7.9 - 9.5					2500	250
AS6-8LF			17.5	11.1 - 12.7					2500	250
AS6-10LF			20.7	12.7 - 15.9					2000	200
AS6-12LF			23.8	15.9 - 19.0					2000	200
AS6-16LF			30.2	22.2 - 25.4					2000	100

ALUMINIUM RIVETS 120° COUNTERSUNK ASC ALUMINIUM RIVET, STEEL MANDREL

Material: Body: Aluminium Alloy 5050

Mandrel: Carbon Steel

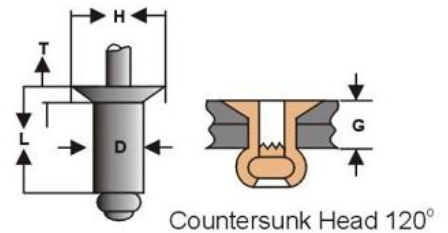

Countersunk Head 120°

COUNTERSUNK RIVETS are for applications where a flush appearance is required.

RIVET CODE	RIVET DIA D INCH MM	DRILL SIZE	RIVET LENGTH MAX MM	GRIP RANGE G	STANDARD STRENGTH		HEAD DIAMETER H (mm)	HEAD THICKNESS T (mm)	BULK QTY	BOX QTY
					LBS (min) SHEAR	TENSILE				
ASC4-3	1/8 3.2	#30 3.3	8.2	3.2 - 4.8	120	150	6.5	1.2	20000	1000
ASC4-4			9.9	4.8 - 6.4					20000	1000
ASC4-6			13.0	7.9 - 9.5					20000	1000
ASC4-8			16.2	9.5 - 12.7					10000	1000
ASC5-4	5/32 4.0	#20 4.1	10.5	4.8 - 6.4	190	230	8.0	1.5	10000	1000
ASC5-6			13.6	6.4 - 9.5					10000	500
ASC5-8			16.8	9.5 - 12.7					10000	500
ASC6-4	3/16 4.8	#11 4.9	11.1	4.8 - 6.4	260	320	9.5	1.6	5000	250
ASC6-6			14.3	7.9 - 9.5					5000	250
ASC6-8			17.5	11.1 - 12.7					5000	250
ASC6-10			20.7	12.7 - 15.9					5000	250
ASC6-16			30.2	15.9 - 25.4					2500	250

PRICES \$ PER 1000 BULK AND BOX PACKS



STEEL RIVETS SS

DOME HEAD - STEEL RIVET, STEEL MANDREL SPECIFICATION GRADE 30



Where joining steel to steel, where tensile or shear strength dictate a stronger rivet; metal cabinets, Shelving, etc. Primarily an interior rivet can be used as exterior rivet provided the rivet or application is painted or coated.

RIVET CODE			RIVET DIA D		DRILL SIZE	RIVET LENGTH MAX MM	STANDARD STRENGTH		GRIP RANGE		BULK	BOX
			INCH	MM			LBS (min)	TENSILE	MM	QTY	QTY	
SS4-1			1/8	3.2	#30 3.3	5.15	260	310	0.8 - 1.6	10000	1000	
SS4-2						6.85			1.6 - 3.2	10000	1000	
SS4-3						8.35			3.2 - 4.8	10000	1000	
SS4-4						9.90			4.8 - 6.4	10000	1000	
SS4-5						11.55			6.4 - 7.9	10000	1000	
SS4-6						13.45			7.9 - 9.5	10000	1000	
SS4-8						16.85			9.5 - 12.7	10000	1000	
SS4-10						20.25			12.7 - 15.9	10000	1000	
SS5-2			5/32	4.0	#20 4.1	7.45	370	470	1.6 - 3.2	10000	1000	
SS5-3						9.05			3.2 - 4.8	10000	1000	
SS5-4						10.55			4.8 - 6.4	10000	1000	
SS5-5						12.05			6.4 - 7.9	10000	1000	
SS5-6						13.75			7.9 - 9.5	10000	500	
SS5-8						16.80			9.5 - 12.7	10000	500	
SS6-1			3/16	4.8	#11 4.9	6.45	540	680	1.6 - 3.2	5000	500	
SS6-2						8.05			1.6 - 3.2	5000	500	
SS6-3						9.65			3.2 - 4.8	5000	500	
SS6-4						11.25			4.8 - 6.4	5000	500	
SS6-5						12.85			6.4 - 7.9	5000	500	
SS6-6						14.45			7.9 - 9.5	5000	500	
SS6-8						17.55			9.5 - 12.7	5000	500	
SS6-10						21.45			12.7 - 15.9	5000	250	
SS6-12						22.65			15.9 - 19.0	5000	250	
SS6-16						30.20			19.0 - 25.4	2000	250	
SB8-4			1/4	6.4	6.5	12.60	1140	1550	1.6 - 6.4	2500	250	
SB8-6						15.80			6.4 - 9.5	2500	250	
SB8-8						19.00			9.5 - 12.7	2500	200	
SB8-12						25.30			15.9 - 19.0	2500	250	
SB8-16						31.50			19.0 - 25.4	2000	100	

LARGE FLANGE - STEEL RIVET, STEEL MANDREL SPECIFICATION GRADE 30

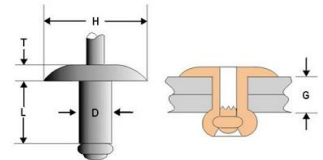

RIVET CODE			RIVET DIA D		DRILL SIZE	RIVET L LENGTH MAX MM	GRIP RANGE G	STANDARD STRENGTH		HEAD DIAMETER	HEAD THICKNESS	BULK	BOX
			INCH	MM				LBS (min)	TENSILE	H (mm)	T (mm)	QTY	QTY
SBL4-4			1/8	3.2	#30 3.3	10.2	4.9 - 6.4	305	410	9.53	1.65	10000	1000
SBL6-4			3/16	4.8	#11 4.9	11.5	1.6 - 6.4	610	870	15.88	2.28	5000	250
SBL6-6						14.6	6.5 - 9.5					5000	250
SBL6-8						17.8	9.6 - 12.7					2000	100
SBL6-12						24.2	16.0 - 19.1					2000	100

PRICES \$ PER 1000 BULK AND BOX PACKS



ALL STAINLESS STEEL SSB-S
BUTTONHEAD - STAINLESS STEEL RIVET, STAINLESS STEEL MANDREL
SPECIFICATION GRADE 304

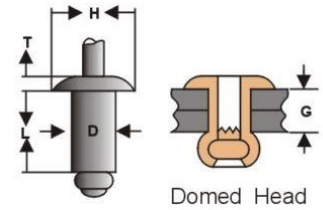

Domed Head

Excellent corrosion resistance, non staining. For food and marine industries and lifetime applications.

RIVET CODE			RIVET DIA D		DRILL SIZE	RIVET L LENGTH MAX MM	GRIP RANGE G	STANDARD STRENGTH		HEAD DIAMETER H (mm)	HEAD THICKNESS T (mm)	BULK QTY	BOX QTY
			INCH	MM				LBS (min)	SHEAR TENSILE				
SSB4-2S			1/8	3.2	#30 3.3	6.7	1.6 - 3.2	420	530	6.5	1.0	20000	1000
SSB4-3S						8.2	3.2 - 4.8					20000	1000
SSB4-4S						9.9	4.8 - 6.4					20000	1000
SSB4-6S						13.0	6.4 - 9.5					10000	1000
SSB4-8S						16.2	9.5 - 12.7					10000	1000
SSB5-2S			5/32	4.0	#20 4.1	7.3	1.6 - 3.2	650	820	8.0	1.2	10000	1000
SSB5-4S						10.5	3.2 - 6.4					10000	1000
SSB5-6S						13.6	6.4 - 9.5					5000	500
SSB6-2S			3/16	4.8	#11 4.9	8.0	1.6 - 3.2	950	1200	9.5	1.5	5000	500
SSB6-4S						11.1	3.2 - 6.4					5000	500
SSB6-6S						14.3	6.4 - 9.5					5000	500
SSB6-8S						17.5	9.5 - 12.7					5000	500
SSB6-10S						20.7	12.7 - 15.9					5000	250
SSB6-12S						23.8	15.9 - 19.1					5000	250
SSB8-4S			1/4	6.4	6.5	12.4	1.6 - 6.4	1700	2100	13.0	2.2	2500	250
SSB8-8S						18.7	6.4 - 12.7					2500	250
SSB8-12S						25.1	12.7 - 19.1					2500	250

ALL STAINLESS STEEL SSBL-S
LARGE FLANGE

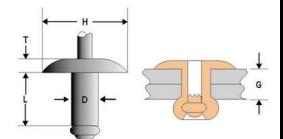
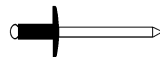

SSBL4-4S			1/8	3.2	#30 3.3	10.2	4.8 - 6.4	420	530	9.6	1.6	10000	500
SSBL6-4S			3/16	4.8	#11 4.9	11.4	4.8 - 6.4	950	1200	16.0	2.3	5000	250
SSBL6-6S						14.6	7.9 - 9.5					5000	250
SSBL6-12S						24.1	16.0 - 19.1					2000	100

ALL STAINLESS STEEL SSC-S
COUNTERSUNK

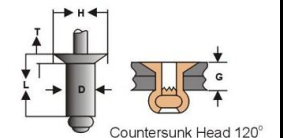
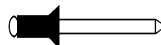

SSC4-3S			1/8	3.2	#30 3.3	8.4	3.2 - 4.8	420	530	6.5	1.0	10000	1000
SSC5-4S			5/32	4.0	#20 4.1	10.6	3.2 - 6.4	650	820	8.0	1.2	5000	250
SSC6-4S			3/16	4.8	#11 4.9	11.2	3.2 - 6.4	1150	1300	9.5	1.5	5000	250
SSC6-6S						14.5	6.4 - 9.5					5000	250

PRICES \$ PER 1000 BULK AND BOX PACKS



NICKEL/COPPER ALLOY RIVETS MB
BUTTONHEAD - NICKEL/COPPER ALLOY RIVET, STEEL MANDREL
SPECIFICATION 400

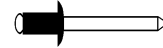

This material gives excellent corrosion resistance for plumbing applications
 With increased shear and tensile strength it is one of the strongest rivets in the product range.

RIVET CODE	OTHER CODE	RIVET DIA		DRILL SIZE		RIVET LENGTH MAX MM	TYPICAL ULTIMATE STRENGTH (LBS)		GRIP RANGE		BULK	BOX
		INCH	MM				SHEAR	TENSILE	MM	QTY	QTY	
MB4-2	73MS4-2	1/8	3.2	#30	3.3	6.85	270	380	1.6 - 3.2	10000	1000	
MB4-3	73MS4-3					8.35			3.2 - 4.8	10000	1000	
MB4-4	73MS4-4					9.95			4.8 - 6.4	10000	1000	
MB4-6	73MS4-6					13.45			6.4 - 9.5	10000	1000	
MB5-2	73MS5-2	5/32	4.0	#20	4.1	7.45	760	870	1.6 - 3.2	10000	500	
MB5-4	73MS5-4					10.55			3.2 - 6.4	10000	500	
MB5-5	73MS5-5					12.05			6.4 - 7.9	10000	500	
MB5-6	73MS5-6					13.75			7.9 - 9.5	5000	500	
MB6-2	73MS6-2	3/16	4.8	#11	4.9	8.05	900	1100	1.6 - 3.2	5000	500	
MB6-3	73MS6-3					9.65			3.2 - 4.8	5000	500	
MB6-4	73MS6-4					11.25			4.8 - 6.4	5000	500	
MB6-5	73MS6-5					12.85			6.4 - 7.9	5000	500	
MB6-6	73MS6-6					14.45			7.9 - 9.5	5000	500	
MB6-8	73MS6-8					17.55			9.5 - 12.7	5000	500	
MB6-10	73MS6-10					21.45			12.7 - 15.9	2500	250	
MB8-4	TLPD850	1/4	6.4	6.5		13.00	1200	1500	Max 7.6	1500	100	
MB8-8	TLPD870					18.00			7.6 - 12.7	1500	100	
120° COUNTERSUNK												
MC4-2	72MS4-2	1/8	3.2	#30	3.3	6.1	270	380	1.6 - 3.2	10000	1000	
MC4-4	72MS4-4					9.3			3.2 - 6.4	10000	1000	
MC4-6	72MS4-6					13.5			6.4 - 9.5	10000	1000	
MC5-4	72MS5-4	5/32	4.0	#20	4.1	10.0	760	870	3.2 - 6.4	10000	1000	
MC6-2	72MS6-2	3/16	4.8	#11	4.9	8.0	900	1100	1.6 - 3.2	5000	500	
MC6-4	72MS6-4					11.5			3.2 - 6.4	5000	500	
MC6-6	72MS6-6					14.7			7.9 - 9.5	5000	500	
MC8-4	TLPK850		6.4	6.5		12.7	1200	1500	1.6 - 6.4	2000	200	

COPPER RIVETS
BUTTON HEAD - COPPER RIVET, STEEL MANDREL
SPECIFICATION 110



Good corrosion resistance, mainly used in plumbing applications and for decorative purposes.

RIVET CODE	OTHER CODE	RIVET DIA		DRILL SIZE		RIVET LENGTH MAX MM	TYPICAL ULTIMATE STRENGTH (LBS)		GRIP RANGE		BULK	BOX
		INCH	MM				SHEAR	TENSILE	MM	QTY	QTY	
CB4-2		1/8	3.2	#30	3.3	6.0	181	227	1.6 - 3.2	10000	1000	
CB4-4						10.0			3.2 - 6.4	10000	1000	

PRICES \$ PER 1000 BULK AND BOX PACKS



ALL ALUMINIUM RIVETS

BUTTONHEAD - ALUMINIUM RIVET, ALUMINIUM MANDREL SPECIFICATION 5052

Used in applications when the finished product must use only aluminium components
Joining plastic to thin aluminium sheet (joining soft to thin materials).

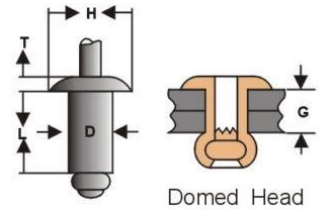

Domed Head

RIVET CODE	RIVET DIA D	DRILL SIZE	RIVET L LENGTH	GRIP RANGE	STANDARD STRENGTH		HEAD DIAMETER	HEAD THICKNESS	BULK QTY	BOX QTY
					LBS (min)	TENSILE				
	INCH MM		MAX MM	G			H (mm)	T (mm)		
AA4-2	1/8 3.2	#30 3.3	6.7	1.6 - 3.2	120	150	6.5	1.2	20000	1000
AA4-3			8.2	3.2 - 4.8					20000	1000
AA4-4			9.9	4.8 - 6.4					20000	1000
AA4-6			13.0	8.0 - 9.5					20000	1000
AA5-2	5/32 4.0	#20 4.1	7.3	0.8 - 3.2	190	230	8.0	1.5	10000	1000
AA5-4			10.5	4.8 - 6.4					10000	1000
AA5-6			13.6	8.0 - 9.6					10000	500
AA6-2	3/16 4.8	#11 4.9	8.0	0.8 - 3.2	260	320	9.5	1.6	10000	500
AA6-4			11.1	4.8 - 6.4					10000	500
AA6-6			14.3	8.0 - 9.6					5000	500
AA6-8			17.5	9.6 - 12.7					5000	500
AA6-12			23.8	15.9 - 19.1					5000	250

PEEL ALUMINIUM RIVETS

BUTTONHEAD - ALUMINIUM RIVET, STEEL STEM ASP- (SPECIFICATION)

Used to fasten to softer materials, wood, plastic widely used in caravans, trailers and furniture.

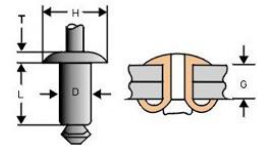

RIVET CODE	RIVET DIA D	DRILL SIZE	RIVET L LENGTH	GRIP G RANGE	STANDARD STRENGTH		HEAD DIAMETER	HEAD THICKNESS	BULK QTY	BOX QTY
					LBS (min)	TENSILE				
	INCH MM		MAX MM	MAX MM			H (mm)	T (mm)		
ASP4-4	1/8 3.2	9/64	12.0	6.40	170	220	6.5	1.2	10000	1000
ASP4-6			15.0	9.50					10000	1000
ASP5-6	5/32 4.0	11/64	16.0	9.50	260	350	8.0	1.5	10000	500
ASP6-5	3/16 4.8	13/64	14.0	7.90	380	500	9.5	1.6	5000	500
ASP6-6			16.0	9.50					5000	500
ASP6-8			19.0	12.70					5000	500
ASP6-10			22.0	15.90					5000	500
ASP6-12			25.0	19.10					5000	500
ASP6-16			32.0	25.40					2500	250

LSR - LOAD SPREAD RIVETS

ACD BUTTONHEAD - ALUMINIUM RIVET, ALUMINIUM MANDREL

During installation the body of the rivet folds into 3 separate legs which create a large bearing surface and distributes the clamp force allowing soft or thin materials to be joined without damage.

Material: Body: Aluminium Alloy (2.5Mg) AA5052
Mandrel: Aluminium Alloy (2.5Mg) AA5052

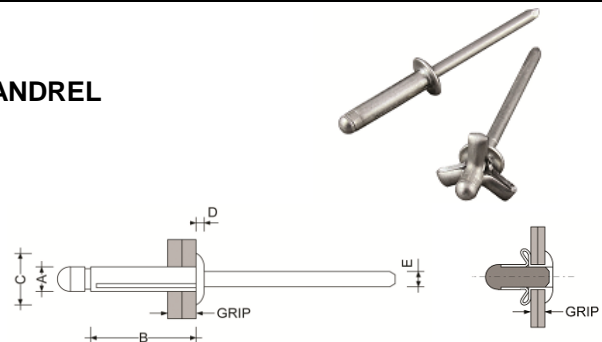

RIVET CODE	RIVET DIA	DRILL SIZE	RIVET LENGTH	GRIP RANGE	STANDARD STRENGTH		HEAD DIAMETER	HEAD THICKNESS	BULK QTY	BOX QTY
					N	TENSILE				
	INCH MM		B MM	MM			C (mm)	D (mm)		
ACD508	5/32 4.0	#20 4.1	18.8	1.0 - 7.0	600	1000	8.0	1.4	4000	1000
ACD612	3/16 4.8	#11 4.9	20.5	1.0 - 9.0	900	1200	9.8	1.8		1000
ACD616			24.0	4.0 - 12.0	900	1200	9.8	1.8	2500	1000



CLOSED END RIVETS ASCE (SEALED)
ALUMINIUM RIVET, STEEL MANDREL
SPECIFICATION IFI-126/GRADE 19

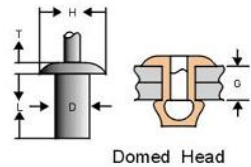

Closed end blind rivets are designed to enclose the mandrel head after fastening and are suitable for many applications which ask for waterproof. Provide a high shear, vibration resistance and pressure tight.

RIVET CODE	RIVET DIA INCH	RIVET DIA MM	DRILL SIZE	DRILL SIZE MM	RIVET L LENGTH MAX MM	GRIP RANGE G	STANDARD STRENGTH		HEAD DIAMETER H (mm)	HEAD THICKNESS T (mm)	BULK QTY	BOX QTY
							LBS (min) SHEAR	TENSILE				
ASCE4-1	1/8	3.2	#30	3.3	7.5	0.8 - 1.6	240	280	6.5	1.3	20000	1000
ASCE4-2					9.1	1.6 - 3.2					20000	1000
ASCE4-3					10.7	3.2 - 4.8					20000	1000
ASCE4-4					12.3	4.8 - 6.4					10000	1000
ASCE4-5					13.9	6.4 - 7.9					10000	1000
ASCE4-6					15.5	7.9 - 9.5					10000	1000
ASCE5-2	5/32	4.0	#20	4.1	9.5	1.6 - 3.2	350	480	8.0	1.7	10000	1000
ASCE5-4					12.7	3.2 - 6.4					10000	500
ASCE5-5					14.3	6.4 - 7.9					10000	500
ASCE6-2	3/16	4.8	#11	4.9	10.3	1.6 - 3.2	500	690	9.5	2.0	10000	500
ASCE6-3					11.9	3.2 - 4.8					10000	500
ASCE6-4					13.5	4.8 - 6.4					5000	500
ASCE6-5					15.0	6.4 - 7.9					5000	500
ASCE6-6					16.7	7.9 - 9.5					5000	500
ASCE6-8					19.8	9.5 - 12.7					5000	500
ASCE6-10					23.0	12.7 - 15.9					5000	250
ASCE6-12					25.1	15.9 - 19.1					5000	250

CLOSED END RIVETS COUNTERSUNK HEAD
5056 ALUMINIUM RIVET, STEEL STEM

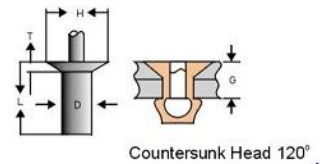

ASCEC4-2				1/8	3.2	#30	3.3	1.6 - 3.2	240	280	6.5	1.6 - 3.2	20000	1000
ASCEC4-3								3.2 - 4.8				3.2 - 4.8	20000	1000
ASCEC6-4				3/16	4.8	#11	4.9	3.2 - 6.4	500	690	9.5	3.2 - 6.4	5000	500
ASCEC6-6								6.4 - 9.5				6.4 - 9.5	5000	500

WATERPROOF RIVETS SSWP (SEALED)
STAINLESS STEEL RIVET, STAINLESS STEEL MANDREL
SPECIFICATION 304

Excellent corrosion resistance, high strength and high weather-proofing capabilities. ie food and marine industries.

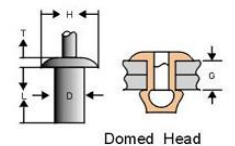
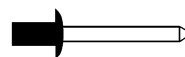

RIVET CODE	RIVET DIA INCH	RIVET DIA MM	DRILL SIZE	DRILL SIZE MM	RIVET L LENGTH MAX MM	GRIP RANGE G	STANDARD STRENGTH		HEAD DIAMETER H (mm)	HEAD THICKNESS T (mm)	BULK QTY	BOX QTY
							LBS (min) SHEAR	TENSILE				
SSWP4-3S	1/8	3.2	#30	3.3	9.9	3.2 - 4.8	450	495	6.0	1.3	10000	1000
SSWP4-4S					11.5	4.8 - 6.4					10000	1000
SSWP4-6S					14.7	6.4 - 9.5					10000	1000
SSWP5-4S	5/32	4.0	#20	4.1	11.9	4.82 - 6.4	675	786	8.0	1.7	5000	500
SSWP6-4S	3/16	4.8	#11	4.9	12.7	4.8 - 6.4	900	990	9.5	2.0	5000	500
SSWP6-6S					15.9	6.4 - 9.5					5000	500

PRICES \$ PER 1000 BULK AND BOX PACKS

Magna-Lok®

The hole-filling fastener with mechanical circle lock and wide grip range.

The 360° solid-circle lock. It's Alcoa Fastening Systems and Rings' answer to loosening and vibration challenges. And it's the reason Magna-Lok® is the world's strongest, most reliable, most consistent blind fastening solution available. The unique locking design creates an internal lock during installation that virtually eliminates pin pushout by mechanically locking the pin to the sleeve. So Magna-Lok fasteners lock flush into place reliably. Permanently.

In lab shear fatigue tests, steel Magna-Lok fasteners outlasted the nearest competitor nearly 20 to 1. Ours lasted 2 million cycles, while theirs lasted only 100,000. In addition, this strength extends to the solid-circle lock design. The expanding sleeve creates a tough, long-lasting joint with a tight, weather-resistant seal. This shield blocks out water and salt, further ensuring the fastener's long, reliable life.

Available Sizes:

3/16", 1/4", 3/8", 1/2"

Materials:

Steel, Aluminum, Stainless Steel

Headstyles:

Protruding, Truss, 100° Flush

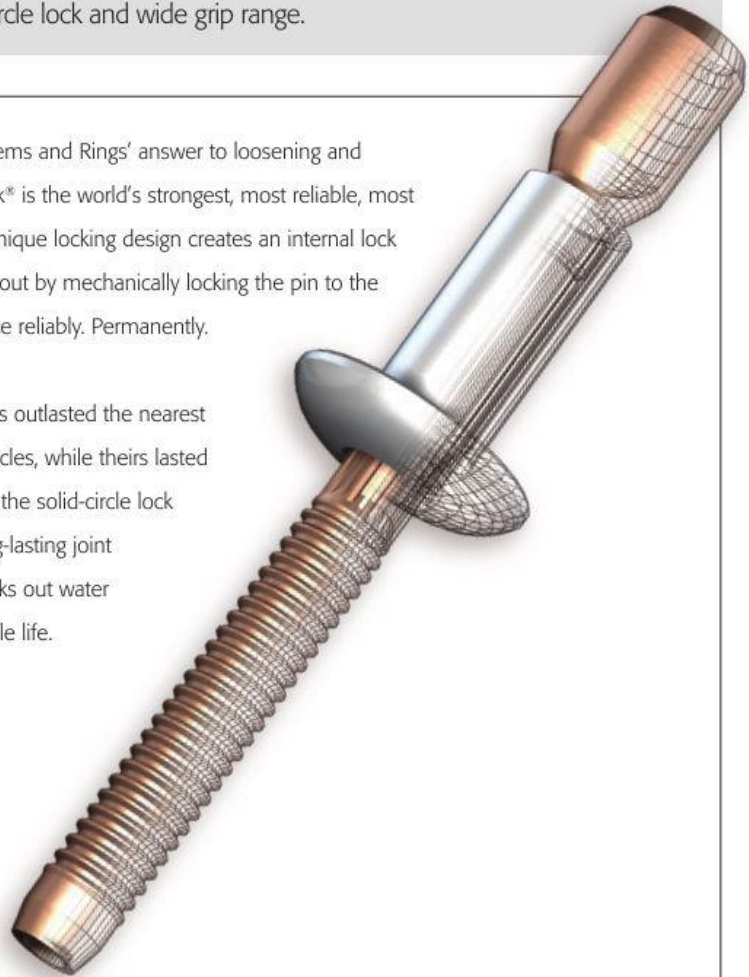

Secure, Fast Installation

1. Flush pin break eliminates grinding and filling, leaving an even surface.
2. Unique, solid-circle lock ensures maximum strength and vibration resistance. The potential for pin push-out is virtually eliminated.
3. Excellent gap pull-out and high retained clamp.
4. Sleeve expands during installation to fill the hole and create a moisture-resistant joint.

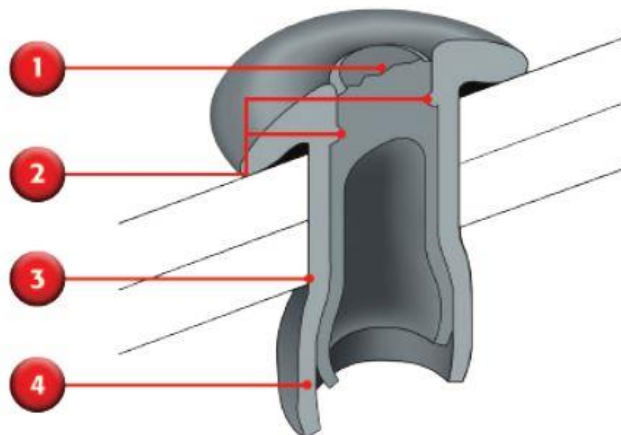



STRUCTURAL FASTENERS

MAGNA-LOK

BLIND FASTENER MADE IN THE USA

Data and Dimensions

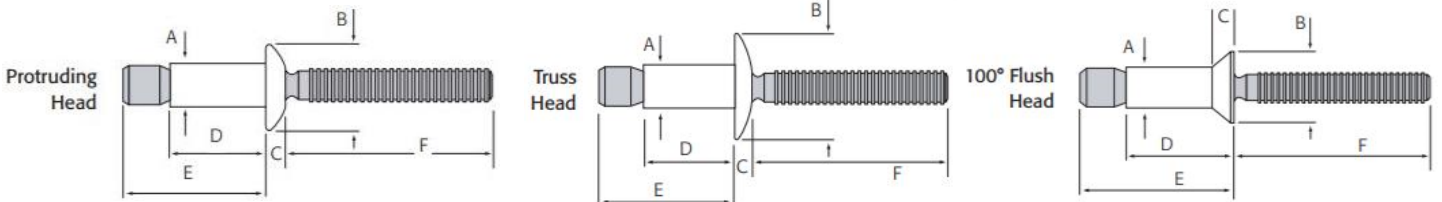

FASTENER CODE	A	B	DIA		DRILL SIZE	TYPICAL SHEAR (lbs)	INSTALLED VALUES			GRIP RANGE MM	C	D	E	F
			INCH	MM			TYPICAL (lbs)	TENSILE	PIN RET					
PROTRUDING HEAD														
STEEL														
MGLP-R6-4	4.78	9.78	3/16"	4.8	5.0	1450	1200	250	1.57 - 6.86	2.16	10.54	17.15	25.40	
MGLP-R6-E	4.78	9.78	3/16"	4.8	5.0				1.57 - 11.10	2.16	14.53	24.13	25.40	
MGLP-R8-6	6.43	13.34	1/4"	6.4	17/64	2750	2200	400	2.03 - 9.53	2.97	14.22	24.64	25.40	
MGLP-R8-E	6.43	13.34	1/4"	6.4	17/64				2.03 - 15.88	2.97	20.57	35.69	25.40	
MGLP-R8-E126	6.43	13.34	1/4"	6.4	17/64				6.22 - 20.00	2.97	24.76	39.87	25.40	
MGLP-R8-18	6.43	13.34	1/4"	6.4	17/64				21.08 - 28.75	2.97	33.27	43.68	25.40	
MGLP-R12-12	9.8	19.99	3/8"	9.5	10.0	6300	5000	1000	3.05 - 14.22	4.45	21.34	41.91	39.24	
MGLP-R12-18	9.8	19.99	3/8"	9.5	10.0				15.8 - 28.57	4.45	35.80	53.30	39.24	
ALUMINIUM														
MGLP-B6-E	4.78	9.78	3/16"	4.8	5.0	700	580	150	1.57 - 11.10	2.16	14.53	24.13	25.40	
MGLP-B8-6	6.43	13.34	1/4"	6.4	17/64	1300	950	220	2.03 - 9.53	2.97	14.22	24.64	25.40	
MGLP-B8-E	6.43	13.34	1/4"	6.4	17/64				2.03 - 15.88	2.97	20.57	35.69	25.40	
MGLP-B12-12	9.8	19.99	3/8"	9.5	10.0	3000	2100	450	3.05 - 14.22	4.45	21.34	41.91	39.24	
STAINLESS STEEL														
MGLP-U6-4	4.78	9.78	3/16"	4.8	5.0	1400	1100	125	1.57 - 6.86	2.16	10.54	17.15	25.40	
MGLP-U6-7	4.78	9.78	3/16"	4.8	5.0				5.44 - 11.10	2.16	14.53	20.96	25.40	
MGLP-U8-6	6.43	13.34	1/4"	6.4	17/64	2500	2000	250	2.03 - 9.53	2.97	14.22	24.64	25.40	
MGLP-U8-10	6.43	13.34	1/4"	6.4	17/64				8.89 - 15.88	2.97	20.57	30.99	25.40	
TRUSS HEAD														
STEEL														
MGLT-R6-4	4.75	12.7	3/16"	4.8	5.0	1450	1200	250	1.57 - 6.86	2.16	10.54	17.15	25.40	
MGLT-R6-E	4.75	12.7	3/16"	4.8	5.0				1.57 - 11.10	2.16	14.53	24.13	25.40	
100° COUNTERSUNK HEAD														
STEEL														
MGL100-R6-6	4.78	8.76	3/16"	4.8	5.0	1450	1200	250	3.18 - 8.41	1.78	12.34	19.35	25.40	
MGL100-R8-8	6.53	10.29	1/4"	6.4	17/64	2750	2200	400	4.06 - 12.07	2.01	16.76	26.90	25.40	
MGL100-R8-12	6.53	10.29	1/4"	6.4	17/64				10.54 - 18.42	2.01	23.11	33.25	25.40	
MGL100-R12-12	9.8	16.05	3/8"	9.5	10.0	6300	5000	1000	6.09 - 19.05	3.40	26.16	42.21	38.93	
ALUMINIUM														
MGL100-B6-6	4.78	8.76	3/16"	4.8	5.0	700	580	150	3.18 - 8.41	1.78	12.34	19.35	25.40	
MGL100-B8-8	6.53	10.29	1/4"	6.4	17/64	1300	950	220	4.06 - 12.07	2.01	16.76	26.90	25.40	
MGL100-B8-12	6.53	10.29	1/4"	6.4	17/64				10.54 - 18.42	2.01	23.11	33.25	25.40	
STAINLESS STEEL														
MGL100-U8-8	6.53	10.29	1/4"	6.4	17/64	2500	2000	250	4.06 - 12.07	2.01	16.76	26.90	25.40	



Magna-Grip®

Offering a wide grip range and uniform installed values.

In applications where a wide grip range is required and a flush pin break to the collar is beneficial, Huck Magna-Grip® is the ideal fastener for the job. In fact, Magna-Grip's wide grip range can replace up to 4 traditional HuckBolts.

Like all Huck engineered fasteners, Magna-Grip offers the highest level of vibration resistance possible. Magna-Grip installs reliably, and consistently provides high, uniform installed values.

Available Sizes:

3/16", 1/4", 5/16", 3/8"

Materials:

Steel, Aluminum

Headstyles:

Button, Truss, Broad Truss, 90° Flush, 98T



Secure, Fast Installation

1. Flush-breaking, lock-groove design provides a wide grip range to reduce inventory requirements.
2. Collar material swaged into the annular pin grooves forms a permanent, vibration-proof connection that promotes increased customer satisfaction and reduced warranty claims.
3. Hole preparation isn't critical. Built-in system values yield high, consistent clamp loads, and gap removal.

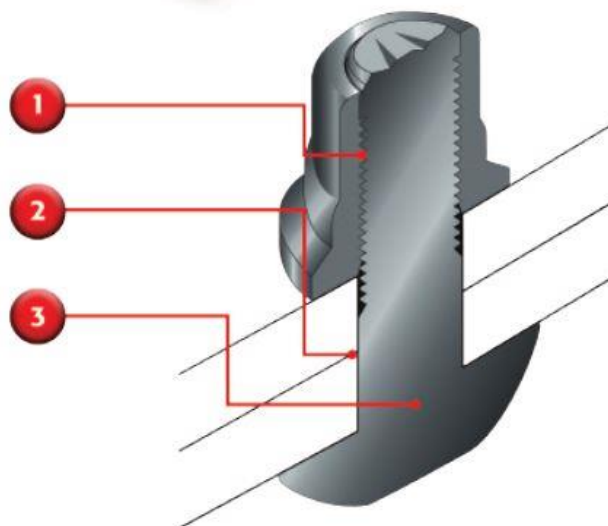



STRUCTURAL FASTENERS

MAGNA-GRIP LOCKBOLT

MADE IN THE USA

Fastener Specifications and Grip Data

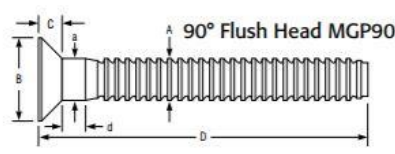
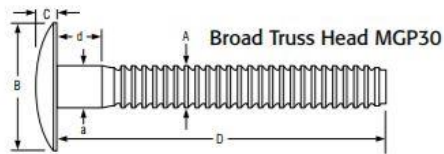
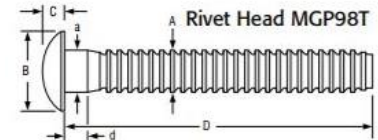
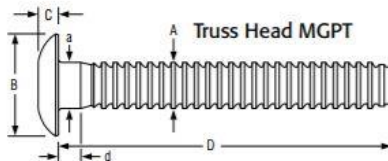
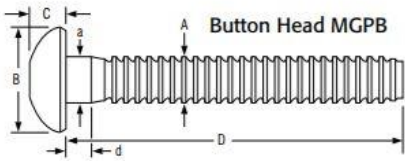

FASTENER CODE	A	B	DIA		DRILL SIZE	TYPICAL SHEAR (lbs)	INSTALLED VALUES			GRIP RANGE MM	C	D	a Ref	d Ref
			INCH	MM			TYPICAL (lbs)	TENSILE	CLAMP					
Button Head - MGPB														
STEEL														
MGPB-R6-10G	4.6-4.7	9.04-10.0	3/16"	4.8	13/64	2000	2700	1500	1.57 - 15.88	2.87-3.18	45.42	4.8-4.9	2.6-3.1	
MGPB-R6-20G									7.92 - 31.75		60.20		7.7-8.1	
MGPB-R8-10G	6.2-6.3	12.0-13.3	1/4"	6.4	17/64	2700	4000	2000	1.57 - 15.88	3.45-3.86	49.91	6.3-6.5	2.7-3.5	
MGPB-R8-20G									7.92 - 31.75		65.02		7.4-8.3	
MGPB-R10-12G	7.8-7.9	15.0-16.6	5/16"	7.9	8.0	3900	6200	2900	3.18 - 19.05	4.60-5.11	59.44	6.9-7.1	6.38Max	
MGPB-R10-22G									15.87 - 34.92		72.14	8.05-8.18	14.2-15.0	
MGPB-R12-14G	9.3-9.5	18.1-19.9	3/8"	9.5	25/64	6000	9000	4000	3.18 - 22.23	5.66-6.30	73.03	9.6-9.8	4.3-5.1	
MGPB-R12-26G									20.62 - 41.28		88.90		20.1-20.9	
ALUMINIUM														
MGPB-E8-10	6.2-6.3	12.0-13.3	1/4"	6.4	17/64	1600	2500	1400	1.57 - 15.88	3.45-3.86	49.91	6.3-6.5	2.7-3.5	
MGPB-E12-14	9.3-9.5	18.1-19.9	3/8"	9.5	25/64	3900	5500	3200	3.18 - 22.23	5.66-6.30	73.03	9.6-9.7	4.3-5.1	
Truss Head - MGPT														
STEEL														
MGPT-R8-10G	6.2-6.3	13.4-15.0	1/4"	6.4	17/64	2700	4000	2000	1.57 - 15.88	2.62 - 2.92	49.91	6.3-6.5	2.7-3.5	
MGPT-R8-20G									7.92 - 31.75		65.02		7.4-8.3	
MGPT-R8-32G									26.97 - 50.80		85.70		7.4-8.3	
Broad Truss Head - MGP30														
STEEL														
MGP30-R8-10G	6.2-6.3	23.8	1/4"	6.4	17/64	2700	4000	2000	3.96 - 15.88	3.51 - 4.11	49.91	6.3-6.5	2.7-3.5	
MGP30-R8-24G									15.88 - 38.1		71.37		13.8-14.6	
MGP30-R12-24G	9.3-9.5	30.1-31.7	3/8"	9.5	25.64	6000	9000	4000	15.88 - 38.1	4.78 - 5.38	85.73	9.6-9.7	16.8-17.6	
Rivet Head - MGP98T														
STEEL														
MGP98T-R6-10G	4.6-4.7	11.43-12.40	3/16"	4.8	13/64	2000	2700	1500	1.57 - 15.88	2.31-2.67	45.42	4.8-4.9	1.9-2.4	
MGP98T-R6-20G									7.92 - 31.75		60.20		7.7-8.1	
ALUMINIUM														
MGP98T-E6-10G	4.6-4.7	11.43-12.40	3/16"	4.8	13/64	1000	1300	800	1.57 - 15.88	2.31-2.67	45.42	4.8-4.9	1.9-2.4	
MGP98T-E6-20G									7.92 - 31.75		60.20		7.7-8.1	
90° Countersunk Head - MGP90														
STEEL														
MGP90-R6-10G	4.6-4.7	8.20-9.12	3/16"	4.8	13/64	2000	2700	1500	1.57 - 15.88	2.34-2.59	45.42	4.8-4.9	8.9 Max	
MGP90-R8-10G	6.2-6.3	11.43-12.40	1/4"	6.4	17/64	2700	4000	2000	1.57 - 15.88	3.02-3.25	49.91	5.5-5.7	9.6 Max	
ALUMINIUM														
MGP90-E6-10	4.6-4.7	8.20-9.12	3/16"	4.8	13/64	1000	1300	800	1.57 - 15.88	2.34-2.59	45.42	4.8-4.9	8.9 Max	



STRUCTURAL FASTENERS

MAGNA-GRIP COLLARS

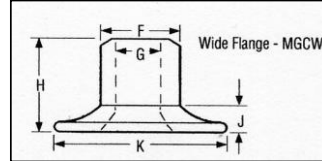
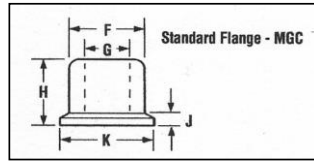

COLLAR CODE	COLLAR TYPE	MATERIAL	DIA INCH	F	G	H	J	K
MGC-R6U	Standard	STEEL	3/16"	7.85 - 7.92	4.83-4.93	6.86 - 7.11	1.07 - 1.27	9.35 - 9.70
MGC-F6	Standard	ALUM	3/16"	7.85 - 7.92	4.83-4.93	6.86 - 7.11	1.07 - 1.27	9.35 - 9.70
MGCW-R6U	Wide	STEEL	3/16"	7.80 - 7.98	4.67-5.00	7.82 - 9.09	1.98 - 2.97	16.26 - 19.38
MGCW-F6	Wide	ALUM	3/16"	7.80 - 7.98	4.67-5.00	7.82 - 9.09	1.98 - 2.97	16.26 - 19.38
MGC-R8U	Standard	STEEL	1/4"	10.24-10.31	6.40-6.48	9.40 - 9.65	1.45 - 1.70	12.45 - 12.95
MGCW-R8U	Wide	STEEL	1/4"	10.24-10.41	6.40-6.48	10.97 - 11.73	2.92 - 3.68	21.72 - 25.40
MGC-F8	Standard	ALUM	1/4"	10.24-10.31	6.40-6.48	9.40 - 9.65	1.45 - 1.70	12.45 - 12.95
MGC-R10U	Standard	STEEL	5/16"	12.78-12.88	7.98-8.08	10.97 - 11.28	1.80 - 2.13	15.54 - 16.18
MGC-R12U	Standard	STEEL	3/8"	15.37-15.47	9.60-9.70	12.70 - 12.95	2.24 - 2.49	18.80 - 19.30
MGC-F12	Standard	ALUM	3/8"	15.37-15.47	9.60-9.70	12.70 - 12.95	2.24 - 2.49	18.80 - 19.30

HUCK INSTALLATION TOOL - LH224

CAN INSTALL THE FOLLOWING FASTENERS WITH CORRECT NOSE ASSEMBLY

TYPE	DIAMETER	NOSE ASSEMBLY CODE
MAGNA-LOK	3/16"	99-3300
	1/4"	99-3301
	3/16" & 1/4"	99-3487A
MAGNA-BULB	3/16"	99-3300
	1/4"	99-3301
MAGNA-GRIP	3/16"	99-3201
	1/4"	99-3204
HUCKTAINER	3/8"	99-3465
C6L HUCKBOLTS	3/16"	99-3003
	1/4"	99-3006



HUCK INSTALLATION TOOL - 256

CAN INSTALL THE FOLLOWING FASTENERS WITH CORRECT NOSE ASSEMBLY

TYPE	DIAMETER	NOSE ASSEMBLY CODE
MAGNA-LOK	3/8"	99-3318
MAGNA-GRIP	5/16"	99-1439
	3/8"	99-1440
	3/16"	99-1053
BOM	1/4"	99-830-1
	5/16"	99-769
C6L HUCKBOLTS	5/16"	99-2558
	1/4"	99-2564





HuckLok®

Wide grip-range and double-locking action for a secure hold.

Featuring a wide grip range and unique double-locking action, the HuckLok® blind rivet combines high shear strength and high pull-up force. Its double-locking action consistently secures the assembly from both sides, resulting in maximum hold and joint integrity. Its large, blind-side footprint prevents pull-through, especially when joining thin or lightweight materials, such as plastics, composites, or any kind of pliable material. Positive mechanical pin retention ensures structural integrity, while annular grooves keep pressure on the back side.

Available Sizes:
3/16", 1/4"

Materials:
Steel

Headstyles:
Protruding, Truss, 100° Oval Flush

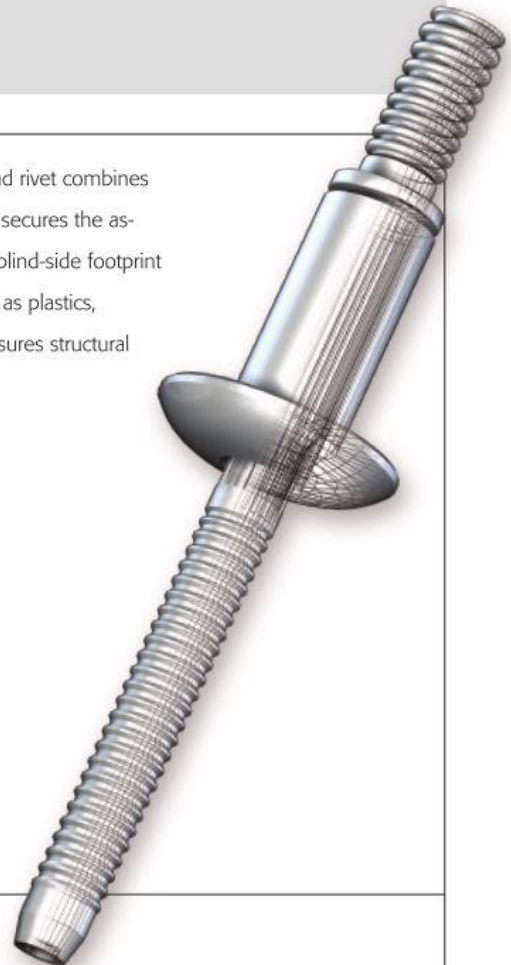
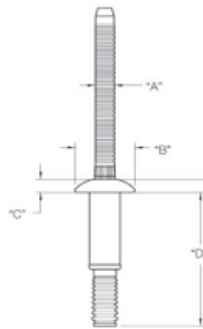

Secure, Fast Installation

1. Breaking flush throughout its grip range, HuckLok allows at-a-glance verification of installation accuracy.
2. Undercut fillet allows seating in burred holes.
3. Solid pin provides exceptionally high strength in the shear plane.
4. Lock groove on pin engages shoulder on rivet head, while the extruded support ring "double locks" the pin within the bulb.

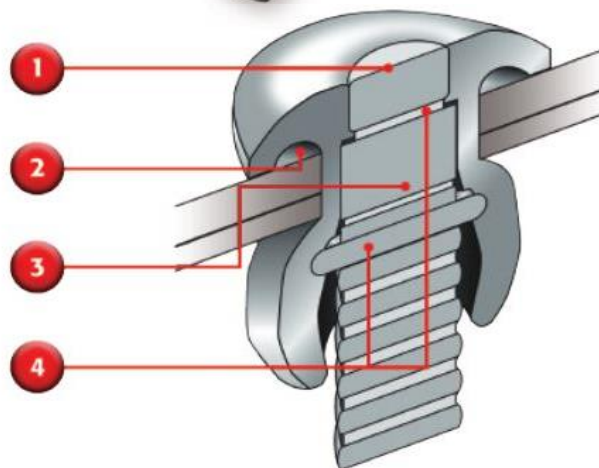

FASTENER CODE	A	B	DIA		DRILL SIZE	TYPICAL SHEAR (lbs)	INSTALLED VALUES		GRIP RANGE MM	C	D
			INCH	MM			MINIMUM TENSILE (lbs)				
PROTRUDING HEAD STEEL											
HKLP-R8-6	6.4	11.9	1/4"	6.4	17/64	3500	1900		2.00 - 9.50	3.00	28.30
HKLP-R8-7									4.80 - 11.10		29.90

Magna-Bulb®

A unique bulbing fastener with high shear strength.

Huck Magna-Bulb® is a unique, clamp-type fastener offering high shear strength in specific applications. Its bulbing action during installation spreads the load over more surface area, supplying a stronger, longer-lasting connection, while offering superior blind side strength. This increased bearing area makes Magna-Bulb ideal for pull-out resistance in thin materials, and oversized or misaligned holes. Positive, mechanical pin-retention ensures structural integrity no matter what the application.

Available Sizes:

3/16", 1/4", 5/16"

Materials:

Steel

Headstyles:

Protruding, Truss, 100° Oval Flush



Secure, Fast Installation

1. Shear ring design promotes bulb formation and grip adjustment for flush break throughout the grip range.
2. The wide blind footprint (bulb) gives the fastener a broader bearing surface, spreading the load out for greater strength and high pull out resistance.
3. Unique solid circle lock ensures maximum strength and resistance to vibration.
4. Breaking flush throughout the entire grip range, the Magna-Bulb fastener eliminates costly cosmetic finish work and ensures "visually" that the fastener has been installed correctly.

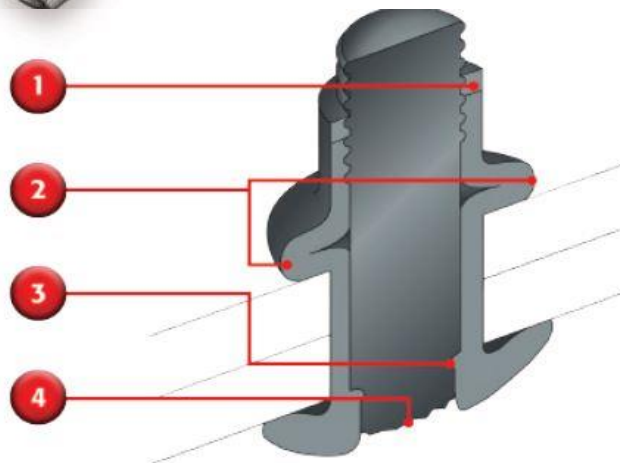



MAGNA-BULB STEEL

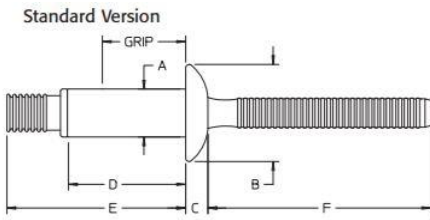

FASTENER CODE	GRIP RANGE		DIA INCH MM	DRILL SIZE	TYPICAL SHEAR (lbs)	INSTALLED VALUES TYPICAL (lbs) TENSILE	C	D	E	F
	A	B								
MBP-R8-M4	6.38	13.46	1/4" 6.4	17/64	2760	2000	3.18	13.77	23.19	27.94
MBP-R8-M5					3000	2000		14.76	23.88	
MBP-R8-M6					3200	2000		15.77	25.40	
MBP-R8-M7					3600	2000		16.76	26.42	
MBP-R8-M8					3600	2000		17.78	27.43	
MBP-R8-M9					3600	2000		18.77	28.45	
MBP-R8-M10					3600	2000		19.79	29.46	
MBP-R8-M11					3600	2000		20.78	30.48	

HUCKTAINER LOCKBOLT

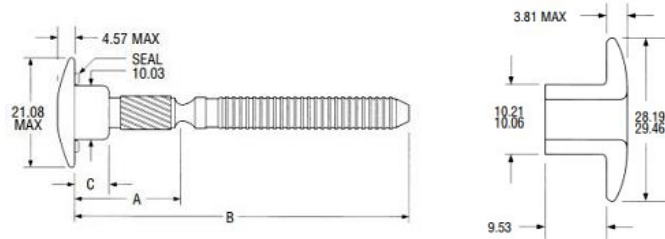

A fastener specifically designed for the commercial vehicle body building industry where G.R.P (glass reinforced plastic) boards are used. This fastener covers a wide grip range, is T.I.R approved, gives improved security to commercial vehicles and has excellent cosmetic appearance qualities. It is T.I.R approved, gives improved security to commercial vehicles and has excellent cosmetic appearance qualities.

HUCKTAINER PIN LOW PROFILE - STEEL

HUCKTAINER COLLAR WIDE BEARING - STEEL

FASTENER CODE	GRIP RANGE		DIA MM	DRILL SIZE	C
	A	B			
HLPP-R12-10	15.85	56.69	10.03	10.5	2.54
HLPP-R12-12	19.02	59.87	10.03	10.5	5.59
HLPP-R12-14	22.20	63.04	10.03	10.5	8.76
HLPP-R12-16	25.37	66.22	10.03	10.5	11.94
HLPP-R12-18	28.55	69.39	10.03	10.5	15.11
HLPP-R12-20	31.72	72.57	10.03	10.5	18.29

COLLAR
HLPS-R12

Huck Tools

The industry's best installation tooling.



Designed to offer the highest levels of ergonomics, productivity, and long life, the Huck line of installation tooling reflects the same level of innovation and quality as its advanced fasteners. Whether it's a Huck hydraulic tool employed in high-volume installation of large diameter HuckBolts, or a smaller pneumatic model used to install blind rivets and small diameter HuckBolts, you can count on these tools to deliver the industry's best value.



2480
The Model 2480 is a very lightweight tool which provides for the high-speed installation of a wide range of HuckBolt and Huck blind bolt fasteners. The tool has only one moving part, resulting in outstanding reliability and minimal maintenance. The tight centerline-to-edge measurement of the Model 2480 and its light weight (2.21 pounds) allow for its use in limited clearance areas.



2581
The Model 2581 is a lightweight tool (only 6.58 pounds) designed for use in a wide range of high-speed production applications. With only one moving part, the tool provides for increased reliability and requires minimal maintenance. An offset piston design allows the Model 2581 to easily fit in limited clearance applications.



HUCK TOOL SELECTION CHART



Fastener	Dia	Pneudraulic Installation Tool	Hydraulic Installation Tool	Nose Assembly	Powerig
Magnalok	3/16	LH-224	2480	99-3300	940-220AUS
	1/4	LH-224	2480	99-3301	940-220AUS
	3/8	256	2480	99-3318	940-220AUS
Hucklok	1/4	LH-224	2480	99-3301	940-220AUS
Magnabulb	1/4	LH-224	2480	99-3301	940-220AUS
Bom	3/16	LH-224	2480	99-994	940-220AUS
	1/4	256		99-830-1	
	5/16	256		99-769	
	3/8	256		99-1272	

Two Piece Huck Bolts



Fastener	Dia	Pneudraulic Installation Tool	Hydraulic Installation Tool	Nose Assembly	Powerig
Magnagrip	3/16	LH-224	2480	99-3201	940-220AUS
	1/4	LH-224	2480	99-3204	940-220AUS
	5/16	256	2581	99-1439	940-220AUS
	3/8	256	2581	99-1440	940-220AUS
C6L	3/16	LH-224	2480	99-3003	940-220AUS
	1/4	LH-224	2480	99-3006	940-220AUS
Hucktainer	3/8	LH-224	2581	99-3465	940-220AUS

2480



2581



LH-224



256



Huck Powerig® Power Source 940-220AUS

The Model 940 Powerig® is a portable unit sized for moderate production and repair applications. This unit features rugged construction for durability in the field and the choice of 115 or 220 Volt AC power. The Model 940 includes a handle for easy transport, simple adjustable hydraulic outputs and quick couplers for connecting installation tool hoses.





STRUCTURAL FASTENERS



PANELOK

Panelok is a highly customised two-piece bolt-& nut type fastener. When installed, a high tensile, low profile splined bolt with an undercut head. Nitrile seal and Scotch-grip patch on the thread matches neatly with a Torx drive T-nut. Externally tamperproof, the assembly is optimal for Metal/wood applications where a Low-Profile finish is desirable on both-sides. Door hardware and frame/bulkhead attachments to GRP applications.

CODE	D1 DIA MM	HOLE SIZE MM	D2 Thread	SEAL COLOUR	STANDARD STRENGTH kn	HEAD DIAMETER H (mm)	HEAD THICKNESS W (mm)	L (mm)
Bolt								
APLB-1014	10.5	10.0	5/16" Unc	BLUE	14KN 20KN	22.0	5.0	22.2
APLB-1016	10.5	10.0	5/16" Unc	YELLOW		22.0	5.0	25.4
APLB-1020	10.5	10.0	5/16" Unc	RED		22.0	5.0	31.8

CODE	H MM	W MM	L MM	D MM	Drive Bit
Nut					
APLN-1008	25	5.0	13.0	10.0	Torx T55
APLN-1010	25	5.0	16.0	10.0	Torx T55
APLN-1016	25	5.0	25.0	10.0	Torx T55

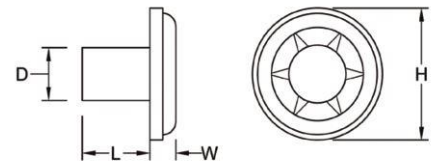

GRIP DATA - Using various bolt/nut combinations

Bolt Code	Nut Code	Grip Range MM
APLB-1014	APLN-1008	21.0 - 24.9
APLB-1014	APLN-1010	22.5 - 28.1
APLB-1016	APLN-1008	24.4 - 28.1
APLB-1016	APLN-1010	25.4 - 31.3
APLB-1020	APLN-1008	30.8 - 34.5
APLB-1020	APLN-1010	30.8 - 37.7
APLB-1020	APLN-1016	35.3 - 47.6

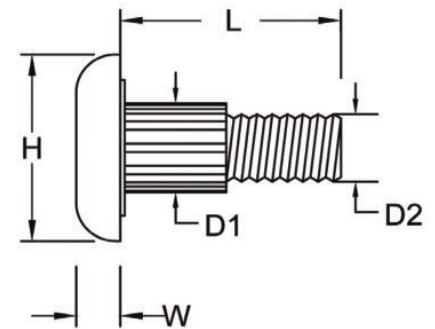



Gesipa BULB-TITE Rivets

Bulb-Tite is the original load spreading rivet. During installation the body of the rivet folds into 3 separate legs which creates a large bearing surface and distributes the clamp force allowing soft or thin materials to be joined without damage. The mandrel of the rivet will break flush with the head over a wide grip range which results in impressive shear strength. BT Rivets are usually supplied with a neoprene washer under the head for a weather tight seal.

Material: Rivet: 5056 Aluminium **Mandrel:** 2017 Aluminium
Steel, zinc-plated (RV6676)

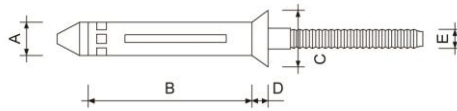
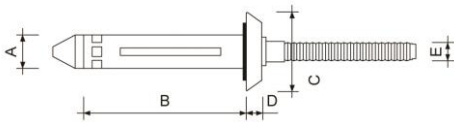

RIVET CODE		RIVET DIA A INCH MM	DRILL SIZE	RIVET B LENGTH MAX MM	GRIP RANGE MM	STANDARD STRENGTH		HEAD DIAMETER C (mm)	HEAD THICKNESS D (mm)Max	PACK SIZE
						KN SHEAR	TENSILE			
Aluminium Rivet / Aluminium Mandrel										
Countersunk Head										
RV6601-6-6		5.2	5.3	22.7	4.7 - 9.5	2.7	2.0	8.6	2.6	3000
RV6601-6-8				25.9	7.9 - 12.7					3000
Dome Head										
RV6606-6-4W		5.2	5.3	19.6	1.6 - 6.4	2.7	2.0	11.3 - 12.5	2.5	3000
RV6606-6-6W				22.7	4.7 - 9.5					3000
RV6606-6-8W				25.9	7.9-12.7					3000
RV6606-6-12W				32.3	14.3-19.1					2000
RV6606-8-4W		6.3	6.4	20.7	1.0 - 6.4	4.2	2.5	13.6 - 14.0	2.9	2000
RV6606-8-6W				23.4	3.2-9.5					2000
RV6605-9-6W		7.7	8.0	28.2	1.1 - 9.5	6.7	4.9	18.3 - 19.4	3.8	1000
RV6605-9-10W				34.5	6.4 - 15.9					1000
RV6605-9-12W				37.7	9.5 - 19.1					1000
Steel Rivet / Steel Mandrel										
RV6676-8-6W		6.3	6.4	23.4	3.2 - 9.5	5.6	4.2	13.6 - 14.0	2.90	1500





THREADED INSERTS - Blind Nuts

Blind nuts can be used in a wide range of applications and are designed to provide a very efficient cost - effective method of placing permanent threads in thin materials. Installed from one side, Blind Nuts are perfect for use in metal, fiberglass and rigid plastic previously to thin for tapped threads. Blind nuts provide a neat appearance and once in place, the internal threads are ready for a screw or bolt.

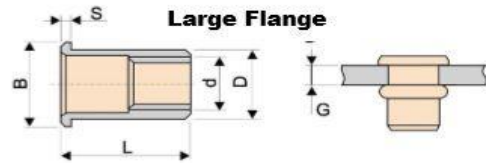

RIVET CODE	THREAD SIZE d	NUT DIA D	NUT LTH L	HOLE SIZE MM	GRIP RANGE G	HEAD DIA B	HEAD THICK S
STEEL FLAT HEAD LARGE FLANGE RIBBED							
BNFS4	M4 X 0.7	5.9	11.6	6.0	0.3 - 2.5	9.0	0.8
BNFS5	M5 X 0.8	6.9	13.0	7.0	0.5 - 3.0	10.0	1.0
BNFS6	M6 X 1.0	8.9	16.0	9.0	0.5 - 4.0	13.0	1.5
BNFS8	M8 X 1.25	10.9	18.0	11.0	0.8 - 4.0	15.0	1.5
BNFS10	M10 X 1.5	12.9	21.0	13.0	1.0 - 5.0	19.0	1.7
BNFS12-5.1	M12 X 1.75	17.4	34.2	17.5	1.6 - 5.1	21.97	1.19
BNFS12-8.9	M12 X 1.75	17.4	34.2	17.5	5.1 - 8.9	21.97	1.19
STAINLESS STEEL LARGE FLANGE - Material 304							
BNFSS4	M4 X 0.7	5.95	12.0	6.0	0.3 - 2.5	9.0	1.0
BNFSS5	M5 X 0.8	6.95	13.0	7.0	0.3 - 3.0	10.0	1.0
BNFSS6	M6 X 1.0	8.95	15.5	9.0	0.5 - 3.0	12.0	1.5
BNFSS6G5	M6 X 1.0	8.95	17.5	9.0	3.0 - 5.0	12.0	1.5
BNFSS8	M8X1.25	10.95	17.5	11.0	0.5 - 3.0	15.0	1.5
BNFSS8G5	M8X1.25	10.95	20.0	11.0	3.0 - 5.5	15.0	1.5
BNFSS10	M10X1.5	12.95	21.0	13.0	1.0 - 3.5	17.0	2.0



ALUMINIUM RIVET NUTS

Large Flange - Ribbed

RIVET CODE ALUM	THREAD SIZE MM	NUT DIA D	NUT LTH L	HOLE SIZE MM	GRIP MAX MM	HEAD DIA B	HEAD THICK S
BNFA4	M4 X 0.7	5.95	10.7	6.0	2.5 - 3.5	9.0	0.8
BNFA5	M5 X 0.8	6.95	10.5	7.0	0.8 - 2.5	10.0	1.0
BNFA6	M6 X 1.0	8.95	13.5	9.0	1.0 - 2.5	12.5	1.5
BNFA8	M8 X 1.25	10.5	13.5	11.0	1.0 - 2.5	14.5	1.5
BNFA10	M10 X 1.5	12.95	14.0	13.0	1.0 - 2.5	16.5	1.5

Easy Steps for Installation

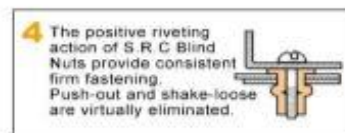
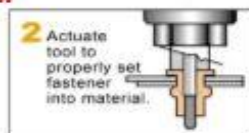
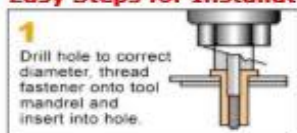

THREADED INSERTS

POLY NUTS (FLUSH MOUNT)

Low profile head. Optimal for low load bearing applications in thin sheet.

Splined body improves torque-to-turn resistance.

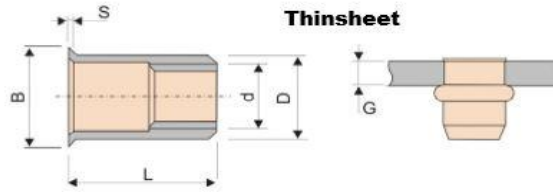

RIVET CODE	THREAD SIZE d	NUT DIA D	NUT LTH L	HOLE SIZE MM	GRIP RANGE G	HEAD DIA B	HEAD THICK S
THIN SHEET (Reduced head) STEEL							
M3RH-A	M3 X 0.5	4.7	9	4.8	0.5 - 1.5	5.3	0.35
M4RH-A	M4 X 0.7	6.3	10.5	6.4	0.5 - 2.5	6.9	0.50
M5RH-A	M5 X 0.8	7.1	12.0	7.2	0.5 - 3.0	7.7	0.60
M6RH-A	M6 X 1.0	9.5	15.0	9.6	0.7 - 3.5	10.2	0.60
M8RH-A	M8 X 1.25	10.5	16.0	10.6	1.0 - 3.5	11.3	0.60
M10RH-A	M10 X 1.5	12.7	20.0	12.8	1.0 - 4.0	13.9	0.60
STAINLESS STEEL COUNTERSUNK HEAD							
5080SS	M4 X 0.7	5.9	10.5	6.0	0.5 - 2.5	7.0	0.50
5090SS	M5 X 0.8	6.9	11.5	7.0	0.5 - 3.0	8.0	0.50
5100SS	M6 X 1.0	8.9	13.5	9.0	0.5 - 3.0	10.0	0.50
5110SS	M8 X 1.25	10.9	15.5	11.0	0.5 - 3.0	12.0	0.50

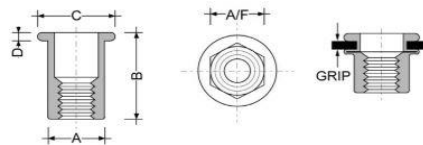

HEX RIVET NUT SERIES

Large flange head, used in conjunction with a hexagon hole to give maximum resistance to applied torque or unscrewing torque.

RIVET CODE	THREAD SIZE d	NUT DIA A	NUT LTH B	HEX HOLE A/F MM	GRIP RANGE G	HEAD DIA C	HEAD THICK D
THIN SHEET (Reduced head) STEEL							
IN9498-0420	M4 X 0.7	6.9	13.0	6.0	0.5 - 2.5	9.0	0.8
IN9498-0530	M5 X 0.8	6.9	13.0	7.0	0.5 - 3.0	10.0	1.0
IN9498-0630	M6 X 1.0	8.9	16.0	9.0	0.5 - 3.0	13.0	1.5
IN9498-0830	M8 X 1.25	10.9	18.0	11.0	0.5 - 3.0	16.0	1.5
IN9498-1035	M10 X 1.5	12.9	24.0	13.0	1.0 - 4.5	19.0	2.0
IN9498-1240	M12 X 1.75	15.9	27.0	16.0	1.5 - 5.0	23.0	2.0

THREAD SETTER KIT



Metric Part No 8731

Contains Setting tool, mandrels & nosepieces

Includes 10 of :

- 3mm Alum rivet nuts
- 4mm Alum rivet nuts
- 5mm Alum rivet nuts
- 6mm Alum rivet nuts

PLUSNUT

The Plusnut has been designed to provide the ultimate pull out strength in thin metals and plastic. Its slotted body splits into four legs providing a wide load bearing surface on the backside of the parent material. The Plusnut also features the widest grip range of any blind threaded nut and is pre-bulbed for easier installation.

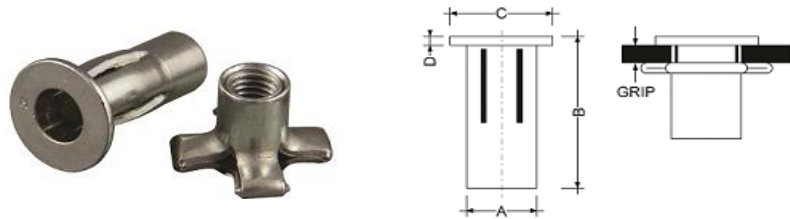

Material: Low Carbon Steel

Finish: Zinc Clear Cr3

PART CODE	THREAD SIZE	NUT DIA	NUT LTH		HOLE SIZE MM	GRIP RANGE G		
		A	B				C	D
PLUSNUT504	M5	7.47	22.0		7.5	0.5 - 4.45	12.7	0.96
PLUSNUT607	M6	8.79	26.9		10.0	0.5 - 7.1	15.9	1.5

JACKNUT

The Jacknut is a flat head slotted body blind rivet nut designed to be installed in soft or brittle materials such as plastic, paper or glass. The 4 legs expand behind the parent material providing excellent pull out resistance especially in soft materials. Suited to light duty applications. (See Plusnut for heavy duty applications)



Material: Low Carbon Steel

Finish: Zinc plate

PART CODE	THREAD SIZE	NUT DIA	NUT LTH		HOLE SIZE MM	GRIP RANGE G		
		A	B				C	D
JACKNUT0601	M6	11.0	18.9		11.0	0.4 - 4.7	16.0	1.8
JACKNUT0602	M6	11.0	23.0		11.0	4.7 - 9.5	16.0	1.8



THREAD SETTER TOOLS

CL-720 THREAD SETTER

Part number CL720

Installs poly nuts and rivet nuts 10-20, 3mm, 4mm steel & alum, (5mm, 6mm, 1/4-20 alum only).
(without mandrel adaptor)



ACCESSORIES

Thread Size	Mandrel Adaptor Code
10-24	0851610
1/4-20	0851615
3mm	0851620
4mm	0851625
5mm	0851630
6mm	0851635



POP® PNT210

Ratchet Tool for Rivet Nuts up to M12
POP® PNT210 is a professional standard heavy duty hand rivet nut tool, with a setting capacity from M6 to M12 in all materials. Supplied with quick-change mandrels and nosepieces to suit M6 to M12 rivet nuts.



POP® PNT410

Lever Tool for Rivet Nuts up to M12
POP® PNT410 is a professional standard heavy duty long lever rivet nut tool with high pulling force. It features stroke adjustment with scale display and quick-change mandrels and nosepieces to suit M5 to M12 rivet nuts.

AIR TOOLS



SRC-806

Adjustable clutch blind nut tool
Capacity M3-M10
8-32, 10-24, 1/4-20, 5/16-18, 3/8-16

Without mandrels & accessories

Mandrel accessories



CODE	SIZE
8063	M3X0.5
8064	M4X0.7
8065	M5X0.8
8066	M6X1.0
8068	M8X1.25
80610	M10X1.5
8061024	10-24(3/16)
80614	1/4-20
806516	5/16-18



SN-12

Pneumatic Nut Tool with Automatic Thread System Design
Setting capacity : M6 To M10 All materials
M12 Steel and Aluminium only.
Thread and unthread nut insert automatically

Spare Mandrels SN-12

CODE	SIZE
SN12-01-M4	M4X0.7
SN12-01-M5	M5X0.8
SN12-01-M6	M6X1.0
SN12-01-M8	M8X1.25
SN12-01-M10	M10X1.5

RIVET TOOLS



HR-702

Quality steel-forged hand riveter with powder-coated surface, the important parts made by the special steel and heat treatment, offer a long life.

Dia	3.2mm 1/8"	4.0mm 5/32"	4.8mm 3/16"	6.4mm 1/4"
Aluminium	X	X	X	
Steel	X	X		
Stainless Steel	X	X		



HR-706 HEAVY DUTY RIVETER

High-Grade Aluminium Die-Cast with Carbon Steel Forged and heat-treated Handle.
Rivet setting capacity : up to 4.8mm (3/16") for all materials.

Dia	3.2mm 1/8"	4.0mm 5/32"	4.8mm 3/16"	6.4mm 1/4"
Aluminium	X	X	X	
Steel	X	X	X	
Stainless Steel	X	X	X	



HR-730

LEVER TOOL LONG ARM RIVETER

Designed for industrial use, lever design reduces physical strength for all rivet sizes.
Rivet setting capacity 3.2, 4.0, 4.8 & 6.4mm all materials.

Dia	3.2mm 1/8"	4.0mm 5/32"	4.8mm 3/16"	6.4mm 1/4"
Aluminium	X	X	X	X
Steel	X	X	X	X
Stainless Steel	X	X	X	X



HR-710

LAZY TONG HAND RIVETER

Designed for industrial use, Slim design for hard to reach riveting application.
Lattice Levering system reduces operator's fatigue.
Rivet setting capacity 3.2, 4.0, 4.8 & 6.4mm all materials.

Dia	3.2mm 1/8"	4.0mm 5/32"	4.8mm 3/16"	6.4mm 1/4"
Aluminium	X	X	X	X
Steel	X	X	X	X
Stainless Steel	X	X	X	X



HP-2 Part number 0800030

The complete hand riveter, supplied with four nosepieces to set 3/32", 1/8", 5/32" 3/16" aluminium and steel rivets.
A quality tool with professional reliability.

Dia	3.2mm 1/8"	4.0mm 5/32"	4.8mm 3/16"	6.4mm 1/4"
Aluminium	X	X	X	
Steel	X	X	X	
Stainless Steel	X	X		

RIVET TOOLS



TT55D

A heavy duty plier type tool suitable for low volume production. Ideal for fastening applications in the field.

Rivet setting capacity:

Dia	3.2mm 1/8"	4.0mm 5/32"	4.8mm 3/16"	6.4mm 1/4"
Aluminium	X	X		
Steel	X	X		
Stainless Steel				



SR1 TRADESMAN'S RIVET TOOL

Sturdy steel construction for longer life
Design allows access into confined spaces
Suitable for light duty field work.

Rivet setting capacity:

Dia	3.2mm 1/8"	4.0mm 5/32"	4.8mm 3/16"	6.4mm 1/4"
Aluminium	X	X	X	
Steel	X	X		
Stainless Steel	X	X		

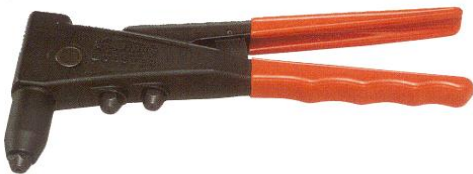

HR-200 LOBSTER RIVET TOOL

Floating jawcase mechanism
For professional and home use
Built in damper reduces weight of shock

Rivet setting capacity:

Dia	3.2mm 1/8"	4.0mm 5/32"	4.8mm 3/16"	6.4mm 1/4"
Aluminium	X	X		
Steel	X	X		
Stainless Steel	X	X		



GESIPA FLIPPER - Made in Germany

Unique Ratchet design requires 40% less force than conventional hand tools. Smart lever design, the force gradually increases as the hands close. Spent mandrel container retains stems.

Rivet setting capacity:

Dia	3.2mm 1/8"	4.0mm 5/32"	4.8mm 3/16"	6.4mm 1/4"
Aluminium	X	X	X	
Steel	X	X		
Stainless Steel	X	X		



GESIPA HN2BT - Made in Germany

Lever Tool for Bulb-Tite up to 7.8mm
Gesipa HN2BT is a heavy duty lever riveting tool with ergonomic grips designed for comfortable and safe operation. Features an integrated mandrel collector which swivels for easy removal. Its lever and gear design significantly reduces the physical force required to set rivets.

Rivet setting capacity:

Dia	3.2mm 1/8"	4.0mm 5/32"	4.8mm 3/16"	6.4mm 1/4"
Aluminium	X	X	X	X
Steel	X	X	X	X
Stainless Steel	X	X	X	X



RIVET TOOLS

FAR RIVET TOOLS - Made in Italy



K39 Hand Tool for Rivets up to 4.8mm Dia

Is a lightweight professional standard hand riveting tool. It utilises robust cast aluminium and steel design and features rivet holding in the nose for one-hand riveting.

Rivet setting capacity:

Dia	3.2mm 1/8"	4.0mm 5/32"	4.8mm 3/16"	6.4mm 1/4"
Aluminium	X	X	X	
Steel	X	X	X	
Stainless Steel	X	X	X	

K25 Lever Tool for Rivets up to 6.4mm Dia

Is a heavy duty lever riveting tool with ergonomic grips designed for comfortable and safe operation. Features an integrated mandrel collector. Its lever and gear design reduced physical force required to set rivets. This tool is ideal for on-site work and low volume installations for larger diameter rivets.

Rivet setting capacity:

Dia	3.2mm 1/8"	4.0mm 5/32"	4.8mm 3/16"	6.4mm 1/4"
Aluminium	X	X	X	X
Steel	X	X	X	X
Stainless Steel	X	X	X	X



K5 LazyTong for Rivets up to 6.4mm Dia

Is a heavy duty lazy tong riveting tool, in robust aluminium and steel construction. The strong steel linkage system is designed for improved mechanical advantage. This tool is supplied with 5 nosepieces.

Rivet setting capacity:

Dia	3.2mm 1/8"	4.0mm 5/32"	4.8mm 3/16"	6.4mm 1/4"
Aluminium	X	X	X	X
Steel	X	X	X	X
Stainless Steel	X	X	X	



Blind Nut Tool

KJ21 Plier Tool for Rivet Nuts up to M8

Is a heavy duty hand rivet nut tool with ergonomic grips designed for comfortable and safe operation. It is longer than most plier type tools creating more leverage and effortless use for the operator. This tool is supplied in a padded plastic carry case with all mandrels and nosepieces for M3 to M8 rivet nuts.

Rivet setting capacity:

Dia	M3	M4	M5	M6	M8
Aluminium	X	X	X	X	X
Steel	X	X	X	X	X
Stainless Steel	X	X	X	X	



PNEUMATIC AIR RIVETERS

RAC83/95

Pneumatic Riveting Tool

Cycle is 100% pneumatic meaning bulletproof reliability
Capacity to 3/16" diameter aluminium rivets.
Optimal for volume installers of standard aluminium rivets
Manufactured by FAR. Italy

Weight: 1.5kgs Stroke: 18mm



Rivet setting capacity:

Dia	3.2mm 1/8"	4.0mm 5/32"	4.8mm 3/16"	6.4mm 1/4"
Aluminium	X	X	X	
Steel	X	X		
Stainless Steel	X	X		



SRC-55P Lightweight design reduces operator fatigue

High placement speed
Longer stroke, Minimized noise
Bottom nosepiece storage
Mandrel collecting container

Weight: 1.2kgs Stroke: 18mm

Rivet setting capacity:

Dia	3.2mm 1/8"	4.0mm 5/32"	4.8mm 3/16"	6.4mm 1/4"
Aluminium	X	X	X	
Steel	X	X	X	
Stainless Steel	X	X		



SRC-56P Lightweight design reduces operator fatigue

High placement speed
Longer stroke, Minimized noise
Bottom nosepiece storage
Mandrel collecting container

Weight: 1.5kgs Stroke: 20mm

Rivet setting capacity:

Dia	3.2mm 1/8"	4.0mm 5/32"	4.8mm 3/16"	6.4mm 1/4"
Aluminium	*	X	X	X
Steel	*	X	X	X
Stainless Steel	*	X	X	

* Nosepiece sold as an optional extra



FAR RAC180 is a lightweight versatile air riveting tool designed for high production applications. As one of the best-selling tools in the Far air tool range it features rivet holding in the nose and vacuum extraction of the of the spent mandrels into the detachable container.

Made in Italy.

Weight: 2.05kgs Stroke: 21mm

Rivet setting capacity:

Dia	3.2mm 1/8"	4.0mm 5/32"	4.8mm 3/16"	6.4mm 1/4"
Aluminium	X	X	X	X
Steel	X	X	X	
Stainless Steel	X	X	X	

PNEUMATIC AIR RIVETERS



SRC-A8H Lightweight design reduces operator fatigue
 High placement speed
 Longer stroke, Minimized noise
 Ergonomic construction allows for swift placement
 Adjustable vacuum airflow minimizes air consumption
 Mandrel collecting container

Weight: 1.7kgs Stroke: 19mm

Rivet setting capacity:

Dia	3.2mm 1/8"	4.0mm 5/32"	4.8mm 3/16"	6.4mm 1/4"
Aluminium	*	*	X	X
Steel	*	*	X	X
Stainless Steel	*	*	X	X

* Nosepiece sold as an optional extra



Taurus 3 is a light weight, high performance air hydraulic riveting tool. It features a patented jaw gripping mechanism. The jaws are pressed onto the mandrel by using compressed air instead of the traditional spring force - no more worn springs to replace. As a result the tool is more reliable and has a longer service life. When the trigger is depressed high pressure air clamps the jaws to the mandrels, the full stroke is utilised to set a rivet. The clamping force is ten times higher than the spring method. The tool uses the same air to set the rivets and extract the mandrel. The tool provides considerable savings on compressed air usage. Made in Germany

Weight: 1.9kgs Stroke: 25mm

Rivet setting capacity:

Dia	3.2mm 1/8"	4.0mm 5/32"	4.8mm 3/16"	6.4mm 1/4"
Aluminium	*	*	X	X
Steel	*	*	X	X
Stainless Steel	*	*	X	X

* Nosepiece sold as an optional extra



RAC171 Air Riveting Tool for Structural Rivets up to 6.4mm

FAR RAC171 is a heavy duty air riveting tool designed for industrial or manufacturing use including installation of structural rivets. With a great price advantage over other equivalent tools, it features rivet holding in the nose and vacuum extraction of the spent mandrels into the detachable container. Made in Italy.

Weight: 2.9kgs Stroke: 25mm

Rivet setting capacity:

Dia	3.2mm 1/8"	4.0mm 5/32"	4.8mm 3/16"	6.4mm 1/4"
Aluminium	*	X	X	X
Steel	*	X	X	X
Stainless Steel	*	X	X	X

* Nosepiece sold as an optional extra

Riveting Tools with Rechargeable 14,4 Volt Li-Ion Battery Gesipa® AccuBird®



The Gesipa® AccuBird® is a professional standard battery tool developed and produced in Germany. Designed to set up to 4.8mm stainless steel rivets this tool provides cable free operation for on site installation or production work.

Supplied in a carry case this tool is electronically controlled and is extremely reliable due to it's low energy transmission via a highly efficient ball screw. Pulling Force: 8.5KN

Manufactured by Gesipa Germany

Weight: 2.2kgs (with battery) Stroke: 20mm

Supplied with two 1.3Ah batteries with charger in plastic carry case.

Rivet setting capacity:

Dia	2.4mm (3/32")	3.2mm 1/8"	4.0mm 5/32"	4.8mm 3/16"
Aluminium	X	X	X	X
Steel	X	X	X	X
Stainless Steel	X	X	X	X

Riveting Tools with Rechargeable 18 Volt Li-Ion Battery Gesipa® AccuBird® Pro



The Gesipa® AccuBird® Pro is the latest innovation for a cordless rivet tool, ideally for on-site installation and heavy industrial production work. It features a faster and more powerful brushless DC (BLDC) motor for increased work flow (4x faster than other battery tools) and longer service life. This tool boasts a remarkable 10KN pulling power.

Supplied in a lightweight plastic carry case with 2 x 2.1Ah batteries and charger.

Manufactured by Gesipa Germany

Weight: 2.0kgs (with battery) Stroke: 25mm

Rivet setting capacity:

Dia	2.4mm (3/32")	3.2mm 1/8"	4.0mm 5/32"	4.8mm 3/16"
Aluminium	X	X	X	X
Steel	X	X	X	X
Stainless Steel	X	X	X	X





Riveting Tools with Rechargeable 14,4 Volt Li-Ion Battery Gesipa® PowerBird®



The Gesipa® PowerBird® is a powerful battery rivet tool capable of setting up to 6.4mm stainless steel rivets and 7.7mm Bulb-Tite® rivets. This tool has all the features of the Accubird but has a larger capacity and higher pulling force ideal for setting structural rivets. This tool has a pulling force of 13KN. Supplied in a lightweight plastic carry case with 2 x 2.6Ah batteries and charger.

Manufactured by Gesipa Germany
Weight: 2.2kgs (with battery) Stroke: 20mm

Rivet setting capacity:

Dia	3.2mm 1/8"	4.0mm 5/32"	4.8mm 3/16"	6.4mm 1/4"
Aluminium	X	X	X	X
Steel	X	X	X	X
Stainless Steel	X	X	X	X

Note will pull 7.7mm Bulb-Tite® Alum Rivets

Riveting Tools with Rechargeable 18 Volt Li-Ion Battery Gesipa® PowerBird® Pro



The Gesipa® PowerBird® Pro is the latest innovation for a cordless rivet tool, idesigned for on-site installation and industrial production work. It features a faster and more powerful brushless DC (BLDC) motor for increased work flow (4x faster than other battery tools) and longer service life. This tool is the high end of the Gesipa® battery rivet tool range and boasts a remarkable 15KN pulling power. Available as the PowerBird® Pro BT for installation of Gesipa® Bulb-Tite® Rivets up to 7.7mm (9/32"). Supplied in a lightweight plastic carry case with 2 x 2.1Ah batteries and charger.

Manufactured by Gesipa Germany
Weight: 2.0kgs (with battery) Stroke: 25mm

Rivet setting capacity:

Dia	3.2mm 1/8"	4.0mm 5/32"	4.8mm 3/16"	6.4mm 1/4"
Aluminium	X	X	X	X
Steel	X	X	X	X
Stainless Steel	X	X	X	X

Note will pull 7.7mm Bulb-Tite® Alum Rivets
Just add 7252237 17/48 BT Nosepiece



SLEEVE ANCHORS

HEX HEAD STEEL YELLOW PASSIVATED



CODE	DESCRIPTION	PACK SIZE	DRILL DIA MM	MINIMUM EMBEDMENT DEPTH MM	FASTENS MATERIALS UP TO MM	ICCONS CODE
HS6525	6.5 X 25mm	100	6.5	20	5	SA06525
HS6535	6.5 X 35mm	100		30	5	SA06535
HS6555	6.5 X 55mm	100		30	25	SA06555
HS6575	6.5 X 75mm	100		30	45	SA06575
HS0840	8.0 X 40mm	100	8	35	5	SA08040
HS0865	8.0 X 65mm	50		35	30	SA08065
HS0885	8.0 X 85mm	50		35	50	SA08085
HS1040	10 X 40mm	50	10	34	6	SA10040
HS1050	10 X 50mm	50		40	10	SA10050
HS1060	10 X 60mm	50		40	20	SA10060
HS1075	10 X 75mm	50		40	35	SA10075
HS1095	10 X 95mm	50		40	55	SA10095
HS10120	10 X 120mm	50		40	80	SA10120
HS1260	12 X 60mm	50	12	50	10	SA12060
HS1275	12 X 75mm	25		50	25	SA12075
HS12100	12 X 100mm	25		50	50	SA12100
HS12130	12 X 130mm	25		50	80	SA12130
HS1665	16 X 65mm	25	16	55	10	SA16065
HS16110	16 X 110mm	10		55	55	SA16110
HS16145	16 X 145mm	10		55	90	SA16145
HS2075	20 X 75mm	10	20	60	15	SA20075
HS20105	20 X 105mm	10		60	45	SA20105
HS20150	20 X 150mm	10		60	90	SA20150

SLEEVE ANCHORS

HEX HEAD 316 STAINLESS STEEL



HS1050SS	10 X 50mm	50	10	40	10	SA10050SS
HS1060SS	10 X 60mm	50		40	20	SA10060SS
HS1075SS	10 X 75mm	50		40	35	SA10075SS
HS1260SS	12 X 60mm	50	12	50	10	SA12060SS
HS1275SS	12 X 75mm	25		50	25	SA12075SS

FLUSH HEAD SLEEVE ANCHORS

Carbon Steel Yellow Passivated



FHS1055	10 X 55mm	50	10	40	15	SAF10055
FHS1065	10 X 65mm	50	10	40	25	SAF10065
FHS1265	12 X 65mm	50	12	50	15	SAF12065
FHS1675	16 X 75mm	25	16	60	15	SAF16075

SLEEVE ANCHORS

COUNTERSUNK (Flush Head) Steel Yellow Passivated



FS6535	6.5 X 35mm	100	6.5	30	5	SACSK065035
FS6555	6.5 X 55mm	100		30	25	SACSK065055
FS6575	6.5 X 75mm	100		30	45	SACSK065075
FS0860	8 X 60mm	50	8	35	25	SACSK08060
FS0885	8 X 85mm	50		35	50	SACSK08085
FS1075	10 X 75mm	50	10	40	35	SACSK10075
FS10100	10 X 100mm	50		40	60	SACSK10100

THRU-BOLT STUD ANCHOR

CARBON STEEL CLASS 5.8 ZINC CLEAR

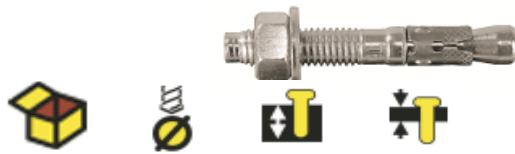

CODE	DESCRIPTION	PACK SIZE	DRILL DIA MM	MINIMUM EMBEDMENT DEPTH MM	FASTENS MATERIALS UP TO MM	ICCONS CODE
PTB12100	12 X 100mm	25	12	60	25	TB12100
PTB16105	16 X 105mm	25	16	80	5	TB16105
PTB16125	16 X 125mm	25		100	10	TB16125
PTB20160	20 X 160mm	10	20	120	20	TB20160

*Other sizes available

THRU-BOLT STUD ANCHOR

CARBON STEEL CLASS 5.8 GALVANISED



PTB12100	12 X 100mm	25	12	60	25	TB12100G
PTB16105	16 X 105mm	25	16	80	5	TB16105G
PTB16125	16 X 125mm	25		100	10	TB16125G
PTB20160	20 X 160mm	10	20	120	20	TB20160G

*Other sizes available

CHISEL POINT STUDS

WITH NUT AND WASHER zinc passivated

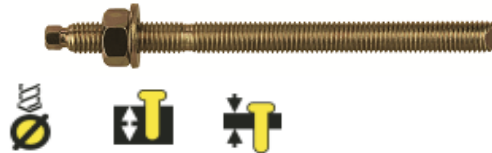

CODE	DESCRIPTION	DRILL DIA MM	MIN DEPTH	FIXTURE THICKNESS	ICCON CODE
STM8110	8mm x 110mm	10	80mm	17	CPS08110
STM10130	10mm x 130mm	12	90mm	28	CPS10130
STM12160	12mm x 160mm	14	110mm	36	CPS12160
STM16190	16mm x 190mm	18	125mm	42	CPS16190
STM20260	20mm x 260mm	24	170mm	72	CPS20260
STM24300	24mm x 300mm	28	210mm	66	CPS24300

CHISEL POINT STUDS

WITH NUT AND WASHER galvanised



STM8110G	8mm x 110mm	10	80mm	17	CPS08110G
STM10130G	10mm x 130mm	12	90mm	28	CPS10130G
STM12160G	12mm x 160mm	14	110mm	36	CPS12160G
STM16190G	16mm x 190mm	18	125mm	42	CPS16190G
STM20260G	20mm x 260mm	24	170mm	72	CPS20260G
STM24300G	24mm x 300mm	28	210mm	66	CPS24300G

BIS-P STYRENE FREE INJECTION SYSTEM

BIS-P420	Styrene Free Injection System 420ml cartridge with 2 nozzles	1
----------	-----------------------------------------------------------------	---

CDISP-VP	Dispensing tool for BIS-P420 Only	1
----------	--------------------------------------	---

BIS-P300	300ml Styrene Free Injection System to suit standard caulking gun	1
----------	----------------------------------------------------------------------	---





WEDGE ANCHOR (DROP-INS)



CODE	DESCRIPTION	PACK SIZE	DRILL DIA MM	MINIMUM EMBEDMENT DEPTH MM	ICCONS CODE
D6M	M6 X 25mm	100	8	27	DM06
D8M	M8 X 30mm	100	10	32	DM08
D10M	M10 X 40mm	50	12	42	DM10
D12M	M12 X 50mm	50	15	52	DM12
D16M	M16 X 65mm	25	20	67	DM16
D20M	M20 X 80mm	25	25	82	DM20

WEDGE ANCHOR (DROP-INS)

SETTING TOOLS



ST6-1/4	To suit M6 & 1/4"	EA	DST06
ST8-5/16	To suit M8 & 5/16"	EA	DST08
ST10-3/8	To suit M10 & 3/8"	EA	DST10
ST12-1/2	To suit M12 & 1/2"	EA	DST12

LIPPED DROP-INS AND SETTING TOOL



LPD10M	M10 X 30mm	50	12	30	DLPM1030
LDST10	10mm Setting Tool Soft Grip	EA			DLST1030

M10 LIPPED DROP-INS IN A BUCKET

LPD10M-BUCKET	500
500 M10 Drop-ins, 2 Drill Bits, Soft Grip Setting Tool	



DLPM1030BK-SDS

HANGERZ FOR CONCRETE

HZCVM10	M10 X 40mm	100
HZCVM10-BUCKET, 3 Drill Bits, 1 Socket & 1 Sleeve		500
HZCM10-D	M10 Socket Driver	EA
HZ6MD-D	Driver Adaptor	EA
HZ6MD	SDS Drill 6mm x 150mm	EA



HANGERZ FOR STEEL

HZSVM10	M10 Rod Hanger for Steel substrates	EA
HZSM10D	M10 Socket Driver	EA



THUNDERBOLT PRO HEX HEAD

CARBON STEEL YELLOW PASSIVATED



CODE	DESCRIPTION	PACK SIZE	DRILL DIA MM	SPANNER MM	FASTENS MATERIALS UP TO MM
BT6530	6.5 X 30mm	100	6.5	10	5
BT6550	6.5 X 50mm	100			25
BT6575	6.5 X 75mm	50			50
BT65100	6.5 X 100mm	50			75
SXTB08050	8 X 50mm	100	8	13	10
SXTB08060	8 X 60mm	100			20
SXTB08075	8 X 75mm	100			35
SXTB08100	8 X 100mm	100			60
SXTB10060	10 X 60mm	50	10	17	10
SXTB10075	10 X 75mm	50			25
SXTB10100	10 X 100mm	50			50
SXTB10120	10 X 120mm	50			70
SXTB12075	12 X 75mm	50	12	19	15
SXTB12100	12 X 100mm	50			40
SXTB12120	12 X 120mm	25			60
SXTB12150	12 X 150mm	25			90
SXTB16100	16 X 100mm	15	16	24	20
SXTB16150	16 X 150mm	15			70

THUNDERBOLT PRO HEX HEAD

CARBON STEEL MECHANICALLY GALVANISED



BTG6530	6.5 X 30mm	100	6.5	10	5
BTG6550	6.5 X 50mm	100			25
BTG6575	6.5 X 75mm	50			50
BTG65100	6.5 X 100mm	50			75
SXTB08050G	8 X 50mm	100	8	13	10
SXTB08060G	8 X 60mm	100			20
SXTB08075G	8 X 75mm	100			35
SXTB08100G	8 X 100mm	100			60
SXTB10060G	10 X 60mm	50	10	17	10
SXTB10075G	10 X 75mm	50			25
SXTB10100G	10 X 100mm	50			50
SXTB10120G	10 X 120mm	50			70
SXTB12075G	12 X 75mm	50	12	19	15
SXTB12100G	12 X 100mm	50			40
SXTB12150G	12 X 150mm	25			90
SXTB16100G	16 X 100mm	15	16	24	20
SXTB16150G	16 X 150mm	15			70

THUNDERBOLT PRO CSK HEAD

COUNTERSUNK HEAD CARBON STEEL YELLOW PASSIVATED



SXTBCS06050G	6.0X50mm	100	6	5 INT HEX	25
SXTBCS08060G	8.0X60mm	100	8	6 INT HEX	15
SXBTCs10060G	10X60mm	100	10	8 INT HEX	20
SXTBCS10100G	10X100mm	50			60
SXTBCS12075G	12X75mm	50	12	10 INT HEX	25
SXTBCS12100G	12X100mm	50			50



HOLLOW WALL ANCHORS



CODE	DESCRIPTION	PACK SIZE	DRILL DIA MM	ICCONS CODE	FASTENS MATERIALS UP TO MM
HWA4XS	8mm x 20mm with M4 screw	100	8	HA4XS	0 to 5
HWA4S	8mm x 32mm with M4 screw	100		HA4S	5 to 10
HWA4SL	8mm x 46mm with M4 screw	100		HA4SL	10 to 18
HWA4L	8mm x 46mm with M4 screw	100		HA4L	18 to 24
HWA6S	10mm x 52mm with M6 screw	50	10	HA6S	10 to 21
HWA8S	11mm x 52mm with M8 screw	50	11	HA8S	10 to 21

HOLLOW WALL ANCHOR SETTING TOOLS

HWAST-200	HEAVY DUTY	EA	HA-STHD
-----------	------------	----	---------



SPRING TOGGLES

ST182	1/8"x2 Round Head	50	10	STR18-2	30
ST3162	3/16"x2 Round Head	50	13	STR316-2	25
ST3163	3/16"x3 Round Head	50		STR316-3	48
ST3164	3/16"x4 Round Head	50		STR316-4	74
STCH3163	3/16"x3 Cup Hook	50		STRCH316-3	50



METAL PIN ANCHORS

MUSHROOM HEAD

MPA0522	5 X 22mm	100	5	MP05022	6.5
MPA6520	6.5 X 20mm	100	6.5	MP65020	6.5
MPA6525	6.5 X 25mm	100		MP65025	10
MPA6532	6.5 X 32mm	100		MP65032	17
MPA6538	6.5 X 38mm	100		MP65038	23
MPA6550	6.5 X 50mm	100		MP65050	35



GRIP NUT

GNM515	5 x 15mm	200	10	5
GNM525	5 x 25mm	100		16
GNM540	5 x 40mm	50		30



GRABCON HEX & COUNTERSUNK HEAD

CODE	DESCRIPTION	PACK SIZE	DRILL DIA MM	MINIMUM EMBEDMENT DEPTH MM	FASTENS MATERIALS UP TO MM
GCCSK05070	5X70MM (3/16X2-3/4) CSK	100	*5/32	25	5
GCHX65032	6.5X32MM (1/4X1-1/4")HEX	100	*3/16	25	6.5
GCHX65083	6.5X83MM (1/4X3-1/4")HEX	100		25	57.5



* Note drill bit included in each box

Buildex®



WALL-MATES

CODE	DESCRIPTION	PACK QTY	PACK TYPE	HANGS UP TO	TYPE
------	-------------	----------	-----------	-------------	------

NYLON

WALLMATEN	Wall-Mate	100	Trade Box	10KGS	Bulk
199600028	Mini Wall-Mate	100	Trade Box	5KGS	Bulk
02391	ZAP-IT Nylon	100	Trade Box		Bulk

METAL

WALLMATEM	Wall-Mate	100	Trade Box	10KGS	Bulk
199900815	Mini Wall-Mate	100	Trade Box	5KGS	Bulk
02392	ZAP-IT Metal	100	Trade Box		Bulk

SUSPENSION ANCHORS

Carbon Steel Yellow Passivated



CODE	DESCRIPTION	PACK SIZE	DRILL DIA MM	MINIMUM EMBEDMENT DEPTH MM	FASTENS MATERIALS UP TO MM
SASUS06535	Suspension 6.5x35mm	100	6.5	35	
SAEB0845	Eye Bolt 8.0x45mm	100	8	45	
SAHB0845	Hook Bolt 8.0x45mm	100	8		
TWTB06060	Tie Wire 6.0x60mm	100	6	40	

NYLON ANCHOR

ROUND HEAD Nail-In



CODE	DESCRIPTION	PACK SIZE	DRILL DIA MM	ICCON CODE	FASTENS MATERIALS UP TO MM
RN0525	5 X 25mm	100	5	NNR05025	6.5
RN0540	5 X 40mm	100		NNR05040	19
RN6525	6.5 X 25mm	100	6.5	NNR65025	6.5
RN6538	6.5 x 38mm	100		NNR65038	19
RN6550	6.5 X 50mm	100		NNR65050	32

MUSHROOM HEAD Nail-In



MN0525	5 X 25mm	100	5	NNM05025	6.5
MN6525	6.5 X 25mm	100	6.5	NNM65025	6.5
MN6538	6.5 X 38mm	100		NNM65038	19
MN6550	6.5 X 50mm	100		NNM65050	32
MN6575	6.5 X 75mm	50		NNM65075	50

DOG-BITES



CODE	DESCRIPTION	PACK SIZE	DRILL DIA MM	MINIMUM EMBEDMENT DEPTH MM
WALLDOG32	3.7 X 32MM Pan Phil Screw	100	5	20

PVC FRAMED WALL PLUGS



CODE	DESCRIPTION		PACK SIZE	DRILL DIA MM	ICCON CODE	SCREW DIA
R25	Red 25mm Plug		1000	6	PVCR25	8g/4mm
R30	Red 30mm Plug		1000		PVCR30	
R38	Red 38mm Plug		1000		PVCR38	
R50	Red 50mm Plug		1000		PVCR50	
G25	Green 25mm Plug		1000	7	PVCG25	10g-12g/
G30	Green 30mm Plug		1000		PVCG30	5 - 5.5mm
G38	Green 38mm Plug		500		PVCG38	
B25	Blue 25mm Plug		1000	8	PVCB25	14g/6 - 7mm
B38	Blue 38mm Plug		500		PVCB38	
B50	Blue 50mm Plug		500		PVCB50	

SCORPION PLUG



SCORPION	Red		600	8.5		7g
----------	-----	--	-----	-----	--	----

NYLON GREY PLUG



NGP0630	6 X 30mm		200	6	3.5 to 4	
NGP0840	8 X 40mm		100	8	5 to 6	
NGP1050	10 X 50mm		50	10	6 to 7.5	
NGP1260	12 X 60mm		25	12	7.5 to 8	

FRIULSIDER NYLON PLUGS

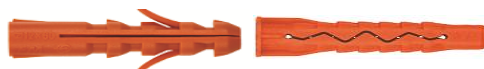

FTU10050	10 X 50mm		50	10	6 to 8	
FMXP10065	10 X 65mm		50	10	6	

POLY - TOGGLES



PTP10	Short 10 - 13		100	8	6 to 8g	10 to 13
PTP13	Medium 13 - 16		100	8	6 to 8g	13 to 16
PTP16	Long 16 - 20		100	8	6 to 8g	16 to 20

CODE	DESCRIPTION		PACK SIZE	DRILL DIA MM	SCREW DIA	
------	-------------	--	-----------	--------------	-----------	--

PLASTIC SPAGHETTI

G550	M5 x 50MTR Green		EA	5.5	3 to 3.5	
R5550	M5.5 X 50MTR Red		EA	6	3.5 to 4	
R5505RP	M5.5 X 5MTR Red		EA	6	3.5 to 4	



FOX FOR FASTENING TO FOAM INSULATED PANELS TORX T40 RECESS



CODE	DESCRIPTION	PACK QTY	MIN INSERTION OF SCREW	SCREW DIA
STYROMATE50	50mm Foam Fastening Plug	50	30mm	10g
STYROMATE85	85mm Foam Fastening Plug	25	40mm	10g

STYROWEDGE - For Fixing to Foam Wallboards.

STYROWEDGE	50
------------	----

Styrowedge gives plumbers, electricians and security services a solution to fixing objects to foam wallboards, can hold up to 20kg.

Installation

1. Take a styrowedge fastener (2 pieces)
2. Using a stanley knife cut a horizontal slot approximately the same width as the styrowedge into the wall
3. Insert styrowedge until flush with (can be done by knocking styrowedge with hammer)
4. Use at least a 40mm screw between 8-12 gauge to fasten between the two styrowedge plates

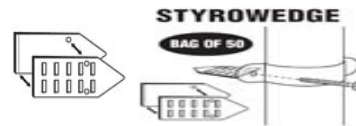

NAILS FOR PNEUMATIC FRAMING TOOL

CODE	DESCRIPTION	CTN QTY
------	-------------	---------

NF75B	75MM X 3.05MM Framing Nails Bright	3000
-------	------------------------------------	------

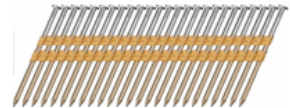

NF75BGAS	75MM X 3.05MM Framing Nails Bright Plus 3 Fuel Cells	3000
----------	---------------------------------------------------------	------



PASLODE NAILS

NF75PASLODE	75MM X 3.05MM Framing Nails Bright Plus 3 Fuel Cells B20547V	3000
-------------	-----------------------------------------------------------------	------

NF75PASLODEG	75MM X 3.05MM Framing Nails Hot Dip Gal Plus 3 Fuel Cells B20569V	3000
--------------	----------------------------------------------------------------------	------



FOAM FILLER EXPANDING POLYURETHANE



ICCONS® FOAMFLO® with CFC-free propellant is a one-component, self expanding, ready-to-use polyurethane foam which is completely harmless to the ozone layer.

Characteristics:

- Available in tool or manual straw delivery systems.
- Excellent adhesion on most substrates (except Teflon, PE and PP).
- High thermal and acoustical insulation.
- Very good filling characteristics.
- Excellent mounting capacities.
- Excellent stability (no shrink or post expansion).

General Applications:

- Sealing of window and door frames.
- Sealing of all openings in roof constructions.
- Sealing of cable - and pipe penetrations.
- Creation of a sound-proof screen.
- Bonding of insulation materials.
- Application of sound-deadening layers.
- Improving thermal insulation in cold store area's.
- Sealing of air conditioning penetrations.

Application:

Shake the aerosol can for at least 20 seconds. For FOAMFLO®F750 fit the supplied adapter on the valve, for FOAMFLO® FT750 fit to dispensing tool (sold separately). Moisten surfaces with a water sprayer prior to application. During application hold can upside down, remove pressure from the applicator/ tool to stop the flow. Fill holes and cavities to 50%, as the foam will expand. Repeat shaking regularly during application. If you have to work in layers repeat moistening after each layer. Fresh foam can be removed using ICCONS® FOAMFLO®CLEANER or acetone. Cured foam can only be removed mechanically. Working temperature 5°C to 35°C. (20°C-25°C recommended).



ICCONS® FOAMFLO®FIRE is a single-component, self expanding, ready to use polyurethane foam with propellants which are completely harmless to the ozone layer. It is fire rated up to 360 minutes in specific configurations (refer to test reports).

Characteristics:

- Fire resistant up to 360 min - (see table over back)
- Efficient seal against smoke and gas
- Does not contain CFC's and H-CFC's
- Excellent adhesion on most substrates (except Teflon, PE and PP)
- High thermal and acoustical insulation
- High bonding strength
- Very good filling characteristics
- Excellent stability: no shrink or post expansion
- Can be painted after full cure



CODE	DESCRIPTION				
F750	750ML Expanding PU Foam with Straw Nozzle				
FT750	750ML Expanding PU Foam for tool delivery system				
FOAMFLOFIRE	750ML Fire Retardant Expanding PU Foam with Straw Nozzle				
FOAMCLEANER500	500ML Cleaner for PU Foam and Tool				
FT-DISPTOOL	Disposable dispensing tool				
FT-PROTOOL	Professional dispensing tool				



FT-DISPTOOL



FT-PROTOOL

PX375 Powder Actuated Tool

.27 CALIBER LOW VELOCITY SEMI AUTOMATIC TOOL



CODE	DESCRIPTION
PX375	Powder Actuated Tool - .27 caliber low velocity semi automatic tool for fixing drive pins up to 75mm

8mm DRIVE PINS



CODE	DESCRIPTION	PACK SIZE	HEAD DIA MM	SHANK DIA MM	PIN LENGTH MM
PXS16	16mm x 8mm head	100	8	3.7	16
PXS19	19mm x 8mm head	100	8	3.7	19
PXS25	25mm x 8mm head	100	8	3.7	25
PXS32	32mm x 8mm head	100	8	3.7	32
PXS38	38mm x 8mm head	100	8	3.7	38
PXS45	45mm x 8mm head	100	8	3.7	45
PXS50	50mm x 8mm head	100	8	3.7	50
PXS57	57mm x 8mm head	100	8	3.7	57
PXS60	60mm x 8mm head	100	8	3.7	60
PXS65	65mm x 8mm head	100	8	3.7	65
PXS70	70mm x 8mm head	100	8	3.7	70
PXS75	75mm x 8mm head	100	8	3.7	75

For use in:

ICCONS PX350, PX375 & PX60M Tools

Also suits most brands of low velocity powder actuated tools.

8mm BALLISTIC POINT STEP DRIVE PIN

For Steel and hard Concrete



PXSC50	50mm x 8mm head	100	8	4	50
PXSC60	60mm x 8mm head	100	8	4	60
PXSC75	75mm x 8mm head	100	8	4	75

6mm DRIVE PINS - High Velocity



PHV50	50mm x 6mm head	100	6	3.7	50
PHV65	65mm x 6mm head	100	6	3.7	65
PHV75	75mm x 6mm head	100	6	3.7	75
PHV90	90mm x 6mm head	100	6	3.7	90

For use in:

Suits most brands of high velocity powder actuated tools.

PXLS - .27 Caliber Load Safety Strip

For use with ICCONS PX350, PX375 & PX60M Tools

Suits most brands of low velocity powder actuated tools

CODE	DESCRIPTION	PACK SIZE
	.27 Cal Green Safety Strip	100
	.27 Cal Yellow Safety Strip	100
	.27 Cal Red Safety Strip	100

GT-6 Gas Tool

Direct Fixing to Metal Stud Partitioning,
Floors, Walls and Ceilings



CODE	DESCRIPTION	PACK SIZE			
GT-6	Long track 40 pin magazine capacity	EA			

GT-6 Pin & Fuel Cell

Standard Pin



CODE	DESCRIPTION	PACK SIZE			
GT6-20	20mm Pin & Fuel Cell	1000			
GT6-25	25mm Pin & Fuel Cell	1000			
GT6-35	35mm Pin & Fuel Cell	1000			

GT-6 HC Ballistic Point Pin

Hardened Pin For Hard Substrates



GT6-HC15	15mm ballistic point pin (for steel) & Fuel Cell	1000			
GT6-HC17	17mm ballistic point pin (for steel & hard concrete) & Fuel Cell	1000			
GT6-HC22	22mm ballistic point pin (for steel & hard concrete) & Fuel Cell	1000			



apolo Cable Tie Mount

Suitable for use with GT-3 & GT-6 Gas Tool



CODE	DESCRIPTION	PACK SIZE	PIPE DIA MM
GT5CTM	Cable Tie Mount for GT-6 & Powers C5 Tools	100	

apolo Conduit Saddle

Suitable for use with GT-3 & GT-6 Gas Tool



GTPVC16	16mm PVC Single	100	16
GTPVC20	20mm PVC Single	100	20
GTPVC25	25mm PVC Single	100	25
GTMT25	25mm Metal Single - Fire Rated	100	25



ROOF ZIPS®

FAST / EASY / VERSATILE



- Versatile fastening solution for fixing to thin metal battens, steel purlins up to 1.5mm and timber battens
- Quick and easy installation
- Superior corrosion protection with Climaseal® coating and Shankguard® feature
- Reduced washer spew for more reliable sealing and less rework on every job.
- Made in Australia

Roof Zips® Hex Head

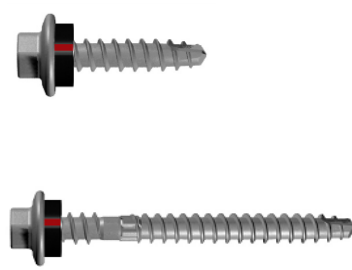

CODE	DESCRIPTION	FINISH	PACK QTY		
ROOFZIP25	M6-11X25MM Full Thread	Class4	500		
ROOFZIP50	M6-11X50MM Part Thread HiGrip	Class4	1000		
ROOFZIP65	M6-11X65MM Part Thread HiGrip	Class4	1000		
Painted Zips					
ROOFZIP25	M6-11X25MM Full Thread Coloured	Class4	500		
ROOFZIP50	M6-11X50MM Part Thread HiGrip Coloured	Class4	1000		
ROOFZIP65	M6-11X65MM Part Thread HiGrip Coloured	Class4	1000		

Batten Zips® Hex Head - No seal

For fastening thin metal battens to timber trusses & steel purlins up to 1.5mm thick.



CODE	DESCRIPTION	FINISH	PACK		
BATTENZIPS	12-11X40MM	Class3	1000		

Ripplezips

A self drilling fastener for valley fixing mini corrugated sheeting to both steel and timber in wall cladding and fencing applications.



CODE	DESCRIPTION	FINISH	PACK		
RIPPLEZIP	10-16X25MM	Class4	1000		
Painted Ripplezip					
RIPPLEZIP	10-16X25MM Coloured	Class4	1000		

Hex Head

For fixing metal to metal: fences, signs, trailers. With seal for roofing applications

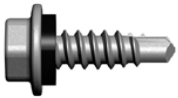

CODE BARE Neo = N	DESCRIPTION	FINISH	PACK QTY		
SDS81812	8-18X12mm Full Thread	Class3	1000		
SDS101616	10-16X16mm Full Thread	Class4	1000		
SDS101616P	10-16X16mm Full Thread Coloured	Class4	1000		
SDS101616ZY	10-16X16mm Full Thread	Z/Y	1000		
SDS101625	10-16X25mm Full Thread	Class4	1000		
SDS101625ZY	10-16X25mm Full Thread	Z/Y	1000		
SDS121420	12-14X20mm Full Thread	Class4	500		
SDS121430	12-14X30mm Full Thread	Class3	1000		



CODE BARE Neo = N	DESCRIPTION	FINISH	PACK QTY		
SDS121445	12-14X45mm Full Thread	Class3	1000		
SDS121468	12-14X65mm Part Thread	Class4	1000		
SDS141022	14-10X22mm Full Thread	Z/Y	1000		
SDS141025	14-10X25mm Full Thread	Class4	500		
SDS141042	14-10X42mm Full Thread	Class4	1000		
SDS142045	14-20X45mm Full Thread	Class4	1000		
SDS141053	14-10X53mm Part Thread	Class4	1000		
SDS141065	14-10X65mm Part Thread	Class4	1000		
SDS141075	14-10X75mm Part Thread	Class4	500		
SDS141095	14-10X95mm Part Thread	Class4	500		

Hex Head - HiGrip® With Seal

For crest fixing corrugated and square rib roofing profiles to steel purlins.



CODE BARE Neo = N	DESCRIPTION	FINISH	PACK QTY		
SDS121455N	12-14X55mm Part Thread HiGrip	Class4	1000		
SDS121468N	12-14X68mm Part Thread HiGrip	Class4	1000		
SDS121480N	12-14X80mm Part Thread HiGrip	Class4	500		

Hex Head - 14 Gauge Long TekS



CODE BARE Neo = N	DESCRIPTION	FINISH	PACK QTY		
SDS1414110	14-14X110MM	Class4	250		
SDS1414125	14-14X125MM	Class4	250		
SDS1414150	14-14X150MM	Class4	250		
SDS1414175	14-14X175MM	Class4	250		
SDS1414205	14-14X205MM	Class4	250		
SDS1414230	14-14X230MM	Class4	250		

AutoTekS Self Drilling Screw Hex Head HiGrip with Seal



CODE BARE Neo = N	DESCRIPTION	FINISH	PACK QTY		
AUTOTEK39	12-14X39mm Part Thread HiGrip	Class4	1000		
AUTOTEK	12-14X50mm Part Thread HiGrip	Class4	1000		
Painted AutoTekS					
AUTOTEK39P	12-14X39mm Coloured Part Thread HiGrip	Class4	1000		
AUTOTEKP	12-14X50mm Coloured Part Thread HiGrip	Class4	1000		

SuperTEKS® Series 500

Designed for fastening to thick steel from 3mm up to 12mm hot rolled steel. Will cut their own mating threads and fasten securely in one simple operation. Has the same twist drill as a conventional Metal TekS®, but with extra long cutting flutes to drill, tap, seal and fasten in one simple operation.

Series 500 Hex Head



CODE BARE Neo = N	DESCRIPTION	FINISH	PACK QTY		
SDSS122438	12-24X38mm Full Thread	Class3	500		
SDSS122450	12-24X53mm Part Thread HiGrip	Class3	1000		
SDSS122468	12-24X68mm Part Thread HiGrip	Class3	1000		
SDSS122485	12-24X85mm Part Thread HiGrip	Class4	500		
SDSS1420150	14-20X150mm Part Thread HiGrip	Class4	250		
SDSS1420200	14-20X200mm Part Thread HiGrip	Class4	150		

Series 500 Wafer Head



CODE BARE	DESCRIPTION	FINISH	PACK QTY		
SDSSW122432	12-24X32mm Full Thread	Class3	500		

Fibreglass TekS Hex Head with 32mm Weatherlock Washer

Fixes fibreglass sheeting to steel purlins between 1mm and 5mm thick. Fibreglass TekS predrills its own expansion hole.



CODE	DESCRIPTION	FINISH	PACK QTY		
SKYLIGHT65	M6.5-14X65mm Part Thread	Class3	500		
SKYLIGHT83	M6.5-14X83mm Part Thread	Class3	250		

Poly Zips Hex Head with 26mm EPDM Washer

Fixes polycarbonate roofing to timber and steel purlins up to 1.2mm thick. Poly Zips predrills its own expansion hole.



CODE	DESCRIPTION	FINISH	PACK QTY		
POLYZIP	M6-11X50mm Part Thread	Class3	250		
POLYZIP65	M6-11X50mm Part Thread	Class3	500		

FibreTEKS®

For fixing non-compressed fibre cement sheeting to timber battens and thin metal battens up to 1.2mm.



CODE	DESCRIPTION	FINISH	PACK QTY		
FIBRETEK25	10-18X25mm Full Thread	Class4	1000		
FIBRETEK30	10-18X30mm Full Thread	Class4	1000		

BUGLE Head - Phillips Recess



CODE	DESCRIPTION	FINISH	PACK QTY		
SDSB61825	6-18X25mm	Z/Y or C3	1000		
SDSB61830	6-18X30mm	Z/Y	1000		
SDSB61840	6-18X40mm	Z/Y	1000		

Pan Head - Phillips Recess



CODE	DESCRIPTION	FINISH	PACK QTY		
SDSP62010	6-20X10mm	Z/Y	1000		
SDSP62020	6-20X20mm	Z/P	1000		
SDSP81812	8-18X12mm	Z/P	1000		
SDSP81816	8-18X16mm	Z/P	1000		
SDSP81822	8-18X22mm	Z/Y	1000		
SDSP81825	8-18X25mm	Z/Y	1000		

Wafer Head - Phillips Recess



CODE	DESCRIPTION	FINISH	PACK QTY		
SDSW101616	10-16X16mm	Z/Y or C3	1000		
SDSW102416C3	10-24X16mm	Class3	1000		
SDSW101622	10-16X22mm	Z/Y or C3	1000		
SDSW102422C3	10-24X22mm	Class3	1000		
SDSW101630	10-16X30mm	Z/Y or C3	1000		
SDSW101640	10-16X40mm	Z/Y or C3	1000		
SDSW102440	10-24X40mm	Class3	1000		
SDSW101650	10-16X50mm	Class3	1000		

Countersunk Head - Phillips Recess



CODE	DESCRIPTION	FINISH	PACK QTY		
SDSC62020	6-20X20mm	Z/Y	1000		
SDSC62030	6-20X30mm	Z/Y	1000		
SDSC81820	8-18X20mm Rib Head	Z/Y	1000		
SDSC81825	8-18X25mm	Z/Y	1000		
SDSC81830	8-18X30mm Rib Head	Z/Y	1000		
SDSC102425	10-24X25mm	Z/Y	1000		
SDSC102430	10-24X30mm	Z/Y	1000		
SDSC102440	10-24X40mm	Z/Y	1000		
SDSC102450	10-24X50mm	Z/Y	500		
SDSC102465	10-24X65mm	Z/Y	500		

Flat Top Self Drilling Screws



CODE	DESCRIPTION	FINISH	PACK QTY		
SDSSH101616	10-16X16mm	Z/Y or C3	1000		

Button Head - Phillips Recess



CODE	DESCRIPTION	FINISH	PACK QTY		
SDSB81812	8-18x12mm	Z/Y or C3	1000		
SDSB81816	8-18X16mm	Z/Y or C3	1000		
SDSB81820	8-18X20mm	Z/Y or C3	1000		
SDSB81825	8-18X25mm	Z/Y or C3	1000		
SDSB81832	8-18X30mm	Z/Y or C3	1000		

Wing TekS - Countersunk Rib Head - Phillips Recess



CODE	DESCRIPTION	FINISH	PACK QTY		
SDSWTC62050	6-20X50mm	Z/Y or C3	1000		
SDSWTC101640	10-16X40mm	Z/Y or C3	1000		
SDSWTC10145	10-16X45mm	Z/Y or C3	1000		
SDSWTC101655	10-16X55mm	Z/Y or C3	1000		
SDSWTC101675	10-16X75mm	Z/Y or C3	1000		
SDSWTC142065	14-20X65mm	Z/Y or C3	1000		

Needle Point - Button Head - Phillips Recess



CODE	DESCRIPTION	FINISH	PACK QTY		
NPB81512	8-15X12mm	Z/Y or C3	1000		
NPB81515	8-15X15mm	Z/Y or C3	1000		
NPB81520	8-15x20mm	Z/Y or C3	1000		
NPB81525	8-15x25mm	Z/Y or C3	1000		
NPB81532	8-15x32mm	Z/Y or C3	1000		

Buildex

Dec-King Screws 316 Stainless Steel



Buildex® Dec-King® is a stainless steel self drilling decking screw for fastening timber decking boards to softwood and treated pine joists.



CODE	DESCRIPTION	FINISH	PACK QTY		
DECKSSM61658	M6-16X58MM SQUARE DRIVE	316 SS	500		

Dec-King Screws 304 Stainless Steel



Buildex® Dec-King® is a stainless steel self drilling decking screw for fastening timber decking boards (12mm-22mm thick) to steel joists between 1.2mm and 2.4mm thick and HRS 1.5mm to 3.0mm thick.



DECKSSM61647	M6-16X47MM SQUARE DRIVE	304 SS	500		
--------------	-------------------------	--------	-----	--	--

Steel House Framing Screws

GX® & NP Frame Screw is for pre-punched holes in frames and trusses. Flush head style to prevent from sitting proud in dimpled holes.



TrustTite Screw - Ideal for the connection of lightweight steel framing into pre-drilled or pre-punched hole.



Buildex GX® Frame Screw & Iccons NP Frame Screw

The GX® or NP Frame Screw is designed for the production of steel frames with pre-punched holes. These Frame Screw are coated with the latest corrosion protection formulated for steel framing. These Frame Screws also offer superior holding strength and easy application.



	CODE	DESCRIPTION	FINISH	PACK QTY		
Buildex	6-201-0021-1MP	6.0x1.0x15.0mm	EziCoat®	3000		
Iccons	NPSFTM0615C3	M6 X 15 NP FRAME	Nautilus3	4000		

Buildex GX® Frame Teks® Screw & Iccons Pancake Self Drilling Screw

These Screw are designed for the assembly of steel frames without pre-punched holes. Also available in EziCoat® a coating specifically formulated for steel framing. The GX® Teks® Frame Screw provides superior holding strength and easy application.



	CODE	DESCRIPTION	FINISH	PACK QTY		
Buildex	6-371-0005-5MP	6.0x1.0x18.0mm	EziCoat®	3000		
Iccons	SDSFTM0618C3	M6 x 18 PANCAKE HD	Nautilus3	2500		

TrussTite Screw

The Buildex TrussTite Screw is designed for the assembly of steel frames into pre-punched or pre-drilled holes. The self tapping point & hex head make the TrussTite easy to align and install.



	CODE	DESCRIPTION	FINISH	PACK QTY		
	6-181-0011-1CS	5/16-12x16mm	EziCoat®	1500		

Hex Head

For fixing cladding and steel roofing profiles to timber.



CODE BARE Neo = N	DESCRIPTION	FINISH	PACK QTY		
T1781520	8-15X20mm Full Thread	Class3	1000		
T17101220	10-12X20mm Full Thread	Class4	1000		
T17101225	10-12X25mm Full Thread	Class4	1000		
T17101225P	10-12X25mm Full Thread Coloured	Class4	1000		
T17101230	10-12X30mm Full Thread	Class4	1000		
T17101230	10-12X30mm Full Thread Coloured	Class4	1000		
T17121125	12-11X25mm Full Thread	Class4	500		
T17121140	12-11X40mm Full Thread	Class3	1000		

HiGrip® With Seal

Crest fixing corrugated roofing profiles to timber battens.



CODE BARE Neo = N	DESCRIPTION	FINISH	PACK QTY		
T17121150	12-11X50mm Part Thread with HiGrip	Class4	1000		
T17121150NP	12-11X50mm Part Thread HiGrip Coloured	Class4	1000		
T17121165	12-11X65mm Part Thread with HiGrip	Class4	1000		
T17121165NP	12-11X65mm Part Thread HiGrip Coloured	Class4	1000		



CODE BARE Neo = N	DESCRIPTION	FINISH	PACK QTY		
T17141025	14-10X25mm Full Thread	Class4	500		
T17141050	14-10X50mm Part Thread	Class4	1000		
T17141065	14-10X65mm Part Thread	Class4	1000		
T17141075	14-10X75mm Part Thread	Class4	500		
T17141090	14-10X90mm Part Thread	Class4	500		
T171410100	14-10X100mm Part Thread	Class4	500		
T171410125	14-10X125mm Part Thread	Class4	250		
T171410150	14-10X150mm Part Thread	Class4	250		
T171410175	14-10X175mm Part Thread	Class4	250		

Type 17 Screws For Timber

Bugle Head Batten - 5mm Hex Recess - Fixing roofing battens rafters or fastening heavy timbers where a flush finish is Required.



CODE	DESCRIPTION	FINISH	PACK QTY		
T17BB141050	14-10X50mm	Z/Y or C3	1000		
T17BB141075	14-10X75mm	C3	500		
T17BB1410100	14-10X100mm	C3	250		
T17BB1410125	14-10X125mm	C3	500		
T17BB1410150	14-10X150mm	C3	250		

Tamper Resistant Head Screws For Timber - Tri-Lob Drive

Security fixings, Security grilles, Signs



CODE	DESCRIPTION	FINISH	PACK QTY		
T17T101225	10-12X25MM	C3	1000		

Timber

SELF DRILLING SCREWS

Countersunk Head - Phillips Recess



CODE	DESCRIPTION	FINISH	PACK QTY		
T17C61825	6-18X25MM	Z/P	1000		
T17C81520	8-15X20MM	Z/P	1000		
T17C81525	8-15X25MM	Z/P	1000		
T17C101230	10-12X30MM	Z/P	1000		
T17C101240	10-12X40MM	Z/P	1000		
T17C101250	10-12X50MM	Z/P	500		
T17C101275	10-12X75MM	Z/P	1000		

Wafer Head - Phillips Recess



CODE	DESCRIPTION	FINISH	PACK QTY		
T17W101225	10-12X25MM	Z/P or C3	1000		
T17W101235	10-12X35MM	Z/P or C3	1000		
T17W101245	10-12X45MM	Z/P or C3	1000		

Pan Head - Phillips Recess



CODE	DESCRIPTION	FINISH	PACK QTY		
T17P81520	8-15X20MM	Z/P or C3	1000		

Buildex® Treated Timber Screws

Buildex

With special Climacoat 3® coating to resist the corrosive effects of treated timbers.



CODE	DESCRIPTION	FINISH	PACK QTY		
TPS81025	8-10X25MM	C3	1000		
TPS81032	8-10X32MM	C3	1000		
TPS81035	8-10X35MM	C3	1000		
TPS81040	8-10X40MM	C3	1000		
TPS81045	8-10X45MM	C3	1000		
TPS81050	8-10X50MM	C3	1000		
TPS81057	8-10X57MM	C3	1000		
TPS10865	10-8X65MM	C3	1000		
TPS10875	10-8X75MM	C3	1000		
TPS108100	10-8X100MM	C3	1000		

Bugle Head Needle Point Fine Thread - Phillips Recess



CODE	DESCRIPTION	FINISH	PACK QTY
B61720	6-17X20MM	Z/P	1000
B61725	6-17X25MM	Z/Y	1000
B61732	6-17X32MM	Z/Y	1000
B61740	6-17X40MM	Z/Y	1000
B61745	6-17X45MM	Z/Y	1000
B71650	7-16X50MM	Z/Y	1000
B81560	8-15X60MM	Z/Y	1000
B81575	8-15X75MM	Z/Y	1000
B10100	10-15X100MM	Z/Y	1000

Bugle Head Needle Point Coarse Thread - Phillips Recess



CODE	DESCRIPTION	FINISH	PACK QTY
B720	7-9X20MM	Z/Y	1000
B725	7-9X25MM	Z/Y	1000
B730	7-9X30MM	Z/Y	1000
B735	7-9X35MM	Z/Y	1000
B741	7-9X41MM	Z/Y	1000
B845	8-9X45MM	Z/Y	1000
B850	8-9X50MM	Z/Y	1000
B101090	10-10X90MM	Z/Y	1000

Chipboard Screws Countersunk Rib Head - Phillips Recess



CODE	DESCRIPTION	FINISH	PACK QTY
CH858	8X5/8 No Nibs	Z/P	1000
CH820	8X20MM	Z/Y	1000
CH825	8X25MM	Z/Y	1000
CH828	8X28MM	Z/Y	1000
CH830	8X30MM	Z/Y	1000
CH832	8X32MM	Z/Y	1000
CH835	8X35MM	Z/Y	1000
CH838	8X38MM	Z/Y	1000
CH840	8X40MM	Z/Y	1000
CH845	8X45MM	Z/Y	1000
CH850	8X50MM	Z/Y	1000
CH860	8X60MM	Z/Y	1000
CH865	8X65MM	Z/Y	1000
CH1075	10X75MM	Z/Y	1000
CH10100	10X100MM	Z/Y	500

Particle board Screws Csk Head - Phillips Recess Full Thread



CODE	DESCRIPTION	FINISH	PACK QTY
PB412	4X1/2	Z/P	1000
PB458	4X5/8	Z/P	1000
PB512	5X1/2	Z/P	1000
PB658	6X5/8	Z/P	1000
PB61	6X1	Z/P	1000
PB6114	6X1.1/4	Z/P	1000
PB611/2	6X1.1/2	Z/P	1000
PB8118	8X1.1/8	Z/P	1000
PB8114	8X1.1/4	Z/P	1000
PB8112	8X1.1/2	Z/P	1000

Director Screws (Connecting Screws) - Pozi Drive



CODE	DESCRIPTION	FINISH	PACK QTY
DIREC550	M5x50mm	Z/P	1000

Superchip Screws Countersunk Head - Pozi Drive



CODE	DESCRIPTION	FINISH	PACK QTY
SU4520	4.5X20MM	Z/P	1000
SU4525	4.5X25MM	Z/P	1000
SU4530	4.5X30MM	Z/P	1000
SU4535	4.5X35MM	Z/P	1000
SU4540	4.5X40MM	Z/P	1000
SU4545	4.5X45MM	Z/P	1000
SU4550	4.5X50MM	Z/P	1000
SU4560	4.5X60MM	Z/P	1000

Plastic Caps & Stickers



CODE	DESCRIPTION	FINISH	PACK QTY
DIRCAPW	Superchip Cap White	White	1000
PHILCAPW	Phillips (Star) Cap White	White	1000
STICKONCAPSW14	14mm Adhesive Screw Caps	White	1000
STICKONCAPSB14	14mm Adhesive Screw Caps	Black	1000
BUMPONSC	Stick on Door Bumper Clear	Clear	1000



Self Tapping Screws Pan & Csk Head - Phillips Recess Zinc Plated



CODE CSK=STSC	DESCRIPTION	FINISH	PACK QTY	
STSP214	2GX1/4 Pan Only	Z/P	1000	
STSP212	2GX1/2 Pan Only	Z/P	1000	
STSP414	4GX1/4	Z/P	1000	
STSP438	4GX3/8	Z/P	1000	
STSP412	4GX1/2	Z/P	1000	
STSP458	4GX5/8	Z/P	1000	
STSP434	4GX3/4	Z/P	1000	
STSP41	4GX1	Z/P	1000	
STSP558	5GX5/8	Z/P	1000	
STSP614	6GX1/4	Z/P	1000	
STSP638	6GX3/8	Z/P	1000	
STSP612	6GX1/2	Z/P	1000	
STSP658	6GX5/8	Z/P	1000	
STSP634	6GX3/4	Z/P	1000	
STSP61	6GX1	Z/P	1000	
STSP6114	6GX1.1/4	Z/P	1000	
STSP6112	6GX1.1/2	Z/P	1000	
STSP62	6GX2	Z/P	1000	
STSP814	8GX1/4	Z/P	1000	
STSP838	8GX3/8	Z/P	1000	
STSP812	8GX1/2	Z/P	1000	
STSP858	8GX5/8	Z/P	1000	
STSP834	8GX3/4	Z/P	1000	
STSP81	8GX1	Z/P	1000	
STSP8114	8GX1.1/4	Z/P	1000	
STSP8112	8GX1.1/2	Z/P	1000	
STSP8134	8GX1.3/4	Z/P	1000	
STSP82	8GX2	Z/P	1000	
STSP1038	10GX3/8	Z/P	1000	
STSP1012	10GX1/2	Z/P	1000	
STSP1058	10GX5/8	Z/P	1000	
STSP1034	10GX3/4	Z/P	1000	
STSP101	10GX1	Z/P	1000	
STSP10114	10GX1.1/4	Z/P	1000	
STSP10112	10GX1.1/2	Z/P	1000	
STSP10134	10GX1.3/4	Z/P	1000	
STSP102	10GX2	Z/P	1000	
STSP103	10GX3	Z/P	1000	
STSP1212	12GX1/2	Z/P	1000	
STSP1258	12GX5/8	Z/P	1000	
STSP1234	12GX3/4	Z/P	1000	
STSP121	12GX1	Z/P	1000	
STSP12114	12GX1.1/4	Z/P	1000	
STSP12112	12GX1.1/2	Z/P	1000	
STSP122	12GX2	Z/P	1000	
STSP1412	14GX1/2 Pan Only	Z/P	1000	



Self Tapping Screws Pan & Csk Head - Phillips Recess 304 Stainless

CODE CSK=STSSC	DESCRIPTION	FINISH	PACK QTY	
STSSP414	4GX1/4	304	1000	
STSSP438	4GX3/8	304	1000	
STSSP412	4GX1/2	304	1000	
STSSP458	4GX5/8	304	1000	
STSSP638	6GX3/8	304	1000	
STSSP612	6GX1/2	304	1000	
STSSP658	6GX5/8	304	1000	
STSSP634	6GX3/4	304	1000	
STSSP61	6GX1	304	1000	
STSSP6114	6GX1.1/4	304	1000	
STSSP6112	6GX1.1/2	304	1000	
STSSP62	6GX2	304	1000	
STSSP838	8GX3/8	304	1000	
STSSP812	8GX1/2	304	1000	
STSSP858	8GX5/8	304	1000	
STSSP834	8GX3/4	304	1000	
STSSP81	8GX1	304	1000	
STSSP8114	8GX1.1/4	304	1000	
STSSP8112	8GX1.1/2	304	1000	
STSSP8134	8GX1.3/4	304	1000	
STSSP82	8GX2	304	1000	
STSSP8212	8GX2.1/2	304	1000	
STSSP83	8GX3	304	1000	
STSSP1012	10GX1/2	304	1000	
STSSP1058	10GX5/8	304	1000	
STSSP1034	10GX3/4	304	1000	
STSSP101	10GX1	304	1000	
STSSP10114	10GX1.1/4	304	1000	
STSSP10112	10GX1.1/2	304	1000	
STSSP102	10GX2	304	1000	
STSSP121	12GX1	304	1000	
STSSP12114	12GX1.1/4	304	1000	
STSSP12112	12GX1.1/2	304	1000	
STSSP122	12GX2	304	1000	
STSSP12212	12GX2.1/2	304	1000	

Self Tapping Screws - Mushroom Head - Phillips Recess Zinc Plated



CODE	DESCRIPTION	FINISH	PACK QTY	
STSM838	8GX3/8	Z/P	1000	
STSM812	8GX1/2	Z/P	1000	
STSM858	8GX5/8	Z/P	1000	
STSM834	8GX3/4	Z/P	1000	
STSM81	8GX1	Z/P	1000	



QUIK DRIVE® PRODUCTS

Quik Drive PRO300SKA Kit

Features:

- Expanded depth settings for high-density flooring materials.
- Non-skid nose increases stability.
- Uniform toenailing and countersink on slick surfaces.
- Easy to master and effortless to use.





Kit Includes:

Note Kit Does Not Include Screw Gun

- QD PRO300SG2A Pro Series Auto-Feed Tool.
- Extension for stand-up driving.
- Milwaukee Adaptor to suit DWSE4000Q, & TKSE2500Q Tools
- Hitachi Adaptor to suit W6V3, W6VA3, W8VB2 & W8V3 Tools
- Makita Adaptor to suit DFS250 (cordless screwgun) FS2500, FS2300 & FS6300
- Tool case..
- For 8-10g and 40 - 75mm strip screws.



CODE		FINISH	BOX QTY		
Fibre Cement Screws - Self Drilling					
Fine thread, #2 drill point with wings, C3 galvanized coating					
#2 square drive, 30 screws per strip.					
CBSDG114SA	8G X 32MM	Class 3	1500		
CBSDG158SA	8G X 42MM	Class 3	1500		
Flooring/Wood Screws - Twin Lead					
Twin thread, sharp point, countersink nibs, #3 square drive.					
WSNTLA134SA	8G x 45mm	Zinc Yellow	2000		
WSNTLA2LSA	8G x 50mm	Zinc Yellow	2000		
WSNTL212SA	8G x 65mm	Zinc Yellow	1500		

DECKING SCREWS

Hardwood - to - Softwood

The DHW hardwood-to-softwood decking screw is specially designed to penetrate the hardest timber decking products with ease. With its unique drill point, it virtually eliminates splitting without pre-drilling. The wings on the shaft counter-bore hard material, allowing the head to countersink easily for a clean finished look. Available in Type 305 stainless steel for addition corrosion protection.



CODE	DESCRIPTION	PACK QTY		
DHWG60SA	10-10X60MM	1000		
	#2 Undersize sq. driver bit included.			



Hardwood - to - Hardwood

The DHSD hardwood-to-hardwood decking screw is specially designed to penetrate the hardest timber decking products with ease. With its unique drill point, it virtually eliminates countersinking and splitting without pre-drilling.

SSDHSD50S	10-11X50MM	1000		
	#2 Sq. driver bit included			

STAPLES

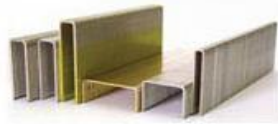

4000 SERIES Crown 4.9mm

Wire Size 0.65 x 0.95 (21 gauge)

CODE	Description	Leg Length	
STAPLES14006	4006 Staples	6mm	
STAPLES14010	4010 Staples	10mm	
STAPLES14014	4014 Staples	14mm	

80 & 680 Series Crown 12.9mm

Wire Size 0.65 x 0.95 (21 gauge)

CODE	Description	Leg Length	
STAPLE8005	8005 Staples	5mm	
STAPLE8006	8006 Staples	6mm	
STAPLE8008	8008 Staples	8mm	
STAPLE8010	8010 Staples	10mm	
STAPLE8012	8012 Staples	12mm	
STAPLE8014	8014 Staples	14mm	
STAPLE8016	8016 Staples	16mm	

6000, 781, 90 & 4800 Series Crown 5.5mm

Wire Size 1.0 x 1.25 (18 gauge)

CODE	Description	Leg Length	
STAPLE781/15	6015 Staples	15mm	
STAPLE781/18	6018 Staples	18mm	
STAPLE781/19	6019 Staples	19mm	
STAPLE781/22	6022 Staples	22mm	
STAPLE781/25	6025 Staples	25mm	
STAPLE781/28	6028 Staples	28mm	
STAPLE781/30	6030 Staples	30mm	
STAPLE781/32	6032 Staples	32mm	
STAPLE781/35	6035 Staples	35mm	
STAPLE781/38	6038 Staples	38mm	

97 SERIES, Kihlberg 690, Crown 4.5mm

Wire Size 0.65 x 0.95 (21 gauge)

CODE	Description	Leg Length	
STAPLES197/10	9710 Staples	10mm	
STAPLES197/12	9712 Staples	12mm	
STAPLES197/14	9714 Staples	14mm	
STAPLES197/16	9716 Staples	16mm	
STAPLES197/19	9719 Staples	19mm	

BRADS & NAILS



C100 BRADS - 18 Gauge C-1

CODE	Description	Leg Length	
C100BRAD10	C110 Brads	10mm	
C100BRAD15	C115 Brads	15mm	
C100BRAD19	C119 Brads	19mm	
C100BRAD25	C125 Brads	25mm	
C100BRAD30	C130 Brads	30mm	
C100BRAD32	C132 Brads	32mm	
C100BRAD35	C135 Brads	35mm	
C100BRAD38	C138 Brads	38mm	
C100BRAD40	C140 Brads	40mm	
C100BRAD45	C145 Brads	45mm	
C100BRAD50	C150 Brads	50mm	

A-11, T50, T200, & 14/34 Series Crown 10.6mm

CODE	Description	Leg Length	
STAPLECR3810	3/8X10mm Staples	10mm	
STAPLECR3812	3/8X12mm Staples	12mm	

6800, 782, Senco M Series Crown 10.2mm

Wire Size 1.0 x 1.25 (18 gauge)

CODE	Description	Leg Length	
STAPLECR3834	3/8X3/4mm Staples	19mm	

C BRADS - 16 Gauge

CODE	Description	Leg Length	
CBRAD19	C19 Brads	19mm	
CBRAD25	C25 Brads	25mm	
CBRAD30	C30 Brads	30mm	
CBRAD32	C32 Brads	32mm	
CBRAD38	C38 Brads	38mm	
CBRAD40	C40 Brads	40mm	
CBRAD45	C45 Brads	45mm	
CBRAD50	C50 Brads	50mm	

COIL NAILS BOSTITCH

CODE	Description	BOX QTY	
FAP27V5	2.5 X 27MM	6000	
FAP32V5	2.5 X 32MM	6000	
FAP32V9	2.9 X 27MM	6000	
NAIL COIL DUO FAST TYPE			
YD32278	27/32 GAL	7200	



Framing Nails see page 40

JOBBER DRILLS

HIGH SPEED STEEL - BULK PACKS

General purpose applications



CODE	DIA	PACK QTY		CODE	DIA MM	PACK QTY	
IMPERIAL				METRIC			
JD164	1/64"	10		JDM18	1.8	10	
JD132	1/32"	10		JDM2	2.0	10	
JD364	3/64"	10		JDM23	2.3	10	
JD116	1/16"	10		JDM24	2.4	10	
JD564	5/64"	10		JDM25	2.5	10	
				JDM28	2.8	10	
JD332	3/32"	10		JDM3	3.0	10	
JD764	7/64"	10		JDM32	3.2	10	
JD18	1/8"	10		JDM33	3.3	10	
JD964	9/64"	10		JDM34	3.4	10	
JD532	5/32"	10		JDM35	3.5	10	
				JDM38	3.8	10	
JD1164	11/64"	10		JDM4	4.0	10	
JD316	3/16"	10		JDM41	4.1	10	
JD1364	13/64"	10		JDM42	4.2	10	
JD732	7/32"	10		JDM43	4.3	10	
JD1564	15/64"	10		JDM45	4.5	10	
				JDM46	4.6	10	
JD14	1/4"	10		JDM48	4.8	10	
JD1764	17/64"	10		JDM49	4.9	10	
JD932	9/32"	10		JDM5	5.0	10	
JD1964	19/64"	10		JDM55	5.5	10	
JD516	5/16"	10		JDM6	6.0	10	
				JDM61	6.1	10	
JD2164	21/64"	10		JDM65	6.5	10	
JD1132	11/32"	5		JDM68	6.8	10	
JD2364	23/64"	5		JDM7	7.0	10	
JD38	3/8"	5		JDM71	7.1	10	
JD2564	25/64"	5		JDM75	7.5	10	
				JDM79	7.9	10	
JD1332	13/32"	5		JDM8	8.0	10	
JD2764	27/64"	5		JDM85	8.5	5	
JD716	7/16"	5		JDM9	9.0	5	
JD2964	29/64"	5		JDM91	9.1	5	
JD1532	15/32"	5		JDM95	9.5	5	
				JDM10	10.0	5	
JD3164	31/64"	5		JDM103	10.3	5	
JD12	1/2"	5		JDM105	10.5	5	
				JDM11	11.0	5	
				JDM111	11.1	5	
METRIC				JDM08	0.8	10	
JDM08	0.8	10		JDM115	11.5	5	
JDM09	0.9	10		JDM12	12.0	5	
JDM1	1.0	10		JDM125	12.5	5	
JDM1.2	1.2	10		JDM127	12.7	5	
JDM1.4	1.4	10		JDM128	12.8	5	
JDM15	1.5	10		JDM13	13.0	5	
JDM17	1.7	10		JDM14	14.0	1	
JDM175	1.75	10					

Ask us about our Suttons Viper Drills

PANEL DRILLS

HIGH SPEED STEEL - BULK PACKS

Developed to drill holes for rivets in flat and curved panels, used in sheet metal fabrication.

CODE	DIA	PACK QTY		
SINGLE ENDED - SHORTIE				
PD30SE	No.30	10		
PD20SE	No.20	10		
PD11SE	No.11	10		
DOUBLE ENDED - TUPOINT				
PD30DE	No.30	10		
PD20DE	No.20	10		
PD11DE	No.11	10		
STUB DRILL				
Rigid twist drill, Shorter than jobber drill.				
SD30	No.30	10		
SD20	No.20	10		
SD11	No.11	10		
SD18	1/8"	10		
SD532	5/32"	10		
SD316	3/16"	10		
SD14	1/4"	10		
COBALT PANEL DRILLS				
PDC30DE	No.30	5		
PDC20DE	No.20	5		
PDC11DE	No.11	5		
JOBBER DRILLS - WIRE GAUGE				
JD30	No.30	10		
JD20	No.20	10		
JD11	No.11	10		
COBALT JOBBER DRILLS HSS-Co Self Centring Point				
Designed for drilling of tough materials such as stainless steel.				
CODE	DIA			
JDCMS1	1.00MM			
JDCMS15	1.50MM			
JDCMS2	2.00MM			
JDCMS25	2.50MM			
JDCMS3	3.00MM			
JDCMS35	3.50MM			
JDCMS4	4.00MM			
JDCMS45	4.50MM			
JDCMS5	5.00MM			
JDCMS55	5.50MM			
JDCMS6	6.00MM			
JDCMS65	6.50MM			
CODE	DIA			
JDCMS7	7.00MM			
JDCMS75	7.50MM			
JDCMS8	8.00MM			
JDCMS85	8.50MM			
JDCMS9	9.00MM			
JDCMS95	9.50MM			
JDCMS10	10.00MM			
JDCMS11	11.00MM			
JDCMS12	12.00MM			
JDCMS13	13.00MM			

DRILL SETS
HIGH SPEED STEEL

suttontools
world class cutting tools



CODE	No. OF DRILLS	DESCRIPTION DRILL SIZES	
IMPERIAL			
S1	13	1/16 - 1/4 in 1/64 rises	
S2	21	1/16 - 3/8 in 1/64 rises	
S3	29	1/16 - 1/2 in 1/64 rises	
METRIC			
SM1	12	1.0 - 6.5mm in 0.5mm rises	
SM2	19	1.0 - 10.0mm in 0.5mm rises	
SM3	25	1.0 - 13.0mm in 0.5mm rises	
Workshop Drill Sets - HSS, Tin Coated Tip			
150BOWS2M	19	1.0 - 10.0mm in 0.5mm rises	
150BOWS3M	25	1.0 - 13.0mm in 0.5mm rises	



GOLD SERIES JOBBER DRILLS - Titanium Coated

M2 HSS - BULK PACKS

General purpose applications





CODE	DIA	PACK QTY		CODE	DIA MM	PACK QTY	
IMPERIAL				METRIC			
JD18T	1/8"	10		JDM2T	3.0	10	
JD964T	9/64"	10		JDM3T	3.0	10	
JD532T	5/32"	10		JDM33T	3.3	10	
				JDM35T	3.5	10	
JD1164T	11/64"	10		JDM4T	4.0	10	
JD316T	3/16"	10		JDM45T	4.5	10	
JD1364T	13/64"	10		JDM49T	4.9	10	
JD732T	7/32"	10					
JD1564T	15/64	10		JDM5T	5.0	10	
				JDM55T	5.5	10	
JD14T	1/4"	10		JDM6T	6.0	10	
JD1764T	17/64"	10		JDM64T	6.4	10	
JD932T	9/32"	10		JDM65T	6.5	10	
JD1964T	19/64"	5		JDM7T	7.0	5	
JD516T	5/16"	5		JDM75T	7.5	5	
JD2164T	21/64"	5		JDM8T	8.0	5	
JD1132T	11/32"	5		JDM85T	8.5	5	
JD2364T	23/64"	5		JDM9T	9.0	5	
JD38T	3/8"	5					
JD2564T	25/64"	5		JDM95T	9.5	5	
				JDM10T	10.0	1	
JD1332T	13/32"	1		JDM105T	10.5	1	
JD2764T	27/64"	1					
JD716T	7/16"	1		JDM11T	11.0	1	
JD2964T	29/64"	1		JDM115T	11.5	1	
				JDM12T	12.0	1	
JD1532T	15/32"	1					
JD3164T	31/64"	1		JDM125T	12.5	1	
JD12T	1/2"	1		JDM13T	13.0	1	



GOLD SERIES PANEL DRILLS - Titanium Coated

M2 HSS - BULK PACKS

CODE	DIA	PACK QTY	
SINGLE ENDED			
PD30SET	No.30	10	
PD20SET	No.20	10	
PD11SET	No.11	10	
DOUBLE ENDED			
PD30DET	No.30	10	
PD20DET	No.20	10	
PD11DET	No.11	10	
STUB DRILL			
Rigid twist drill, Shorter than jobber drill.			
SD30T	No.30	10	
SD20T	No.20	10	
SD11T	No.11	10	

REDUCED SHANK DRILLS



HIGH SPEED STEEL

CODE	DIA INCH	DIA MM		CODE	DIA INCH	DIA MM	
10MM (3/8) DIA SHANK							
RSD1238	1/2						
12.5MM (1/2") DIA SHANK - Overall length 152mm (6")							
RSD13		13.0		RSD2532	25/32		
				RSD20		20.0	
RSD1732	17/32						
RSD135		13.5		RSD1316	13/16		
				RSD21		21.0	
RSD14		14.0					
RSD916	9/16			RSD2732	27/32		
RSD145		14.5					
				RSD22		22.0	
RSD15		15.0		RSD78	7/8		
RSD1932	19/32						
				RSD23		23.0	
RSD155		15.5		RSD2932	29/32		
RSD58	5/8						
RSD16		16.0		RSD1516	15/16		
				RSD24		24.0	
RSD165		16.5					
RSD2132	21/32			RSD3132	31/32		
RSD17		17.0		RSD25		25.0	
RSD1116	11/16			RSD1	1		
RSD175		17.5		RSD26		26.0	
				RSD1132	1-1/32		
RSD18		18.0		RSD1116	1-1/16		
RSD2332	23/32			RSD28		28.0	
RSD185		18.5		RSD118	1-1/8		
RSD19		19.0					
RSD34	3/4						
RSD195		19.5					



GLASS & TILE DRILLS - Tungsten Carbide Tipped



Sometimes called Spear Point Drills, This design is intended to produce clean holes in ceramic tiles, Porcelain and glass. Not suitable for toughened glass, need to be used at a slow speed, non impact, with suitable coolant.

GD3	3.0MM	1/8"		GD65	6.5MM		
GD4	4.0MM	5/32"		GD8	8.0MM	5/16"	
GD5	5.0MM	3/16"		GD10	10.0MM	3/8"	
GD6	6.0MM	1/4"		GD12	12.0MM	1/2"	

Core Bits - Diamond

6.00mm

Diamond Tile Core bits have diamond encrusting for wet drilling only.

For drilling glazed and polished porcelain, sandstone, terracotta & ceramics.

Code : COREDRILL6



MASONRY DRILLS

TUNGSTEN CARBIDE TIPPED



Tradesman quality for rotary and percussion drilling for use in natural and artificial stone, masonry brickwork and concrete.

DIAMETER MM	DIAMETER INCH	CODE	OVERALL LENGTH MM	SHANK MM	WALL PLUG COLOUR		
SF - Standard Fixing							
3.0	1/8	MD3SF	70		Yellow		
4.0	5/32	MD4SF	75		Yellow		
5.0	3/16	MD5SF	85		White		
5.5	7/32	MD55SF	95		Red		
6.0		MD6SF	100		Red		
6.5	1/4	MD65SF	100		Green		
7.0	9/32	MD7SF	100		Green		
8.0	5/16	MD8SF	120		Blue		
10.0	3/8	MD10SF	120		Orange		
SB - Single Brick							
5.0	3/16	MD5SB	150		White		
5.5	7/32	MD55SB	150		Red		
6.0		MD6SB	150		Red		
6.5	1/4	MD65SB	150		Green		
7.0	9/32	MD7SB	150		Green		
8.0	5/16	MD8SB	150		Blue		
10.0	3/8	MD10SB	150		Orange		
11.0	7/16	MD11SB	150	10	Grey		
12.0	15/32	MD12SB	150	10	Grey		
13.0	1/2	MD13SB	150	10			

**Make it
Snappy®
Tools**



Proudly Made In The USA



SNAPPY BITS

Drill Adaptors



Code	Imperial Size		Metric Size		
42008	1/8"	#30	2.95 to 3.26		
42011	11/64"	#20	4.22 to 4.50		
42012	3/16"	#11	4.57 to 4.85		

Countersinks Gold Screw



Code	Imperial Size	Hardwood	Softwood	Counterbore	
43008	1/8"	8g Screws	10g Screws	3/8"	
43009	9/64"	10g Screws	12g Screws	1/2"	
43011	11/64"	10g Screws	12g Screws	1/2"	

Quick Change Chuck -



Code	Accepts				
40011	1/4" Hex				

MASONRY DRILLS
TUNGSTEN CARBIDE TIPPED
SDS MULTI-FIT



ARS CODE	ICCONS CODE	DIA MM	OVERALL LENGTH MM	WORKING LENGTH MM		
MHD5110	HB05.0-110	5.0	110	50		
MHD5160	HB05.0-160	5.0	160	100		
MHD5210	HB05.0-210	5.0	210	150		
MHD55110	HB05.5-110	5.5	110	50		
MHD55160	HB05.5-160	5.5	160	100		
MHD55210	HB05.5-210	5.5	210	150		
MHD6110	HB06.0-110	6.0	110	50		
MHD6160	HB06.0-160	6.0	160	100		
MHD6210	HB06.0-210	6.0	210	150		
MHD65110	HB06.5-110	6.5	110	50		
MHD65160	HB06.5-160	6.5	160	100		
MHD65210	HB06.5-210	6.5	210	150		
MHD65360	HB06.5-360	6.5	360	300		
MHD7110	HB07.0-110	7.0	110	50		
MHD7160	HB07.0-160	7.0	160	100		
MHD8110	HB08.0-110	8.0	110	50		
MHD8160	HB08.0-160	8.0	160	100		
MHD8210	HB08.0-210	8.0	210	150		
MHD8260	HB08.0-260	8.0	260	200		
MHD10110	HB10.0-110	10.0	110	50		
MHD10160	HB10.0-160	10.0	160	100		
MHD10210	HB10.0-210	10.0	210	150		
MHD10260	HB10.0-260	10.0	260	200		
MHD10460	HB10.0-460	10.0	460	400		
MHD12160	HB12.0-160	12.0	160	100		
MHD12210	HB12.0-210	12.0	210	150		
MHD12260	HB12.0-260	12.0	260	200		
MHD12450	HB12.0-450	12.0	450	400		
MHD13160	HB13.0-160	13.0	160	100		
MHD14250	HB14.0-250	14.0	250	200		
MHD16160	HB16.0-160	16.0	160	100		
MHD16200	HB16.0-210	16.0	200	150		
MHD16300	HB16.0-300	16.0	300	250		
MHD18200	HB18.0-200	18.0	200	150		
MHD18450	HB18.0-450	18.0	450	400		
MHD20200	HB20.0-200	20.0	200	150		
MHD20450	HB20.0-450	20.0	450	400		
MHD22250	HB22.0-250	22.0	250	200		
MHD25250	HB25.0-250	25.0	250	200		
MHD25450	HB25.0-450	25.0	450	400		
MHD26250	HB26.0-250	26.0	250	200		

AUGER BITS

POWER SERIES
HIGH GRADE ALLOY STEEL



For fast cutting through holes in timber such as fence posts and railway sleepers.

CODE	DIA MM	OVERALL LENGTH MM	FLUTE LENGTH MM	HEX SHANK MM
AB6160	6.0	160	100	5.00
AB8170	8.0	170	100	6.35
AB8225	8.0	225	165	6.35
AB10190	10.0	190	120	6.35
AB10250	10.0	250	190	6.35
AB12270	12.0	270	195	9.00
AB13190	13.0	190	120	6.35
AB14290	14.0	290	210	9.00
AB16200	16.0	200	130	6.35
AB16290	16.0	290	210	9.00
AB20210	20.0	210	140	8.60
AB20330	20.0	330	240	9.00
AB25210	25.0	210	140	8.60
AB25330	25.0	330	240	9.00

SPADE BITS

METRIC CODE	SIZE
SB6	6mm
SB8	8mm
SB10	10mm
SB12	12mm
SB14	14mm
SB16	16mm
SB18	18mm
SB19	19mm
SB20	20mm
SB22	22mm
SB25	25mm
SB28	28mm
SB32	32mm
SB35	35mm
SB38	38mm



SPADE BIT SET - SUTTON

CODE	SIZE
SS6	

Bit sizes are 16, 19, 22, 25, 32
Plus 150mm Long Extension

SPADE BIT EXTENSION 300MM

Code: SBEXT300



Trefolex Cutting Compound

500ml

Code: Trefolex

Trefolex is a green coloured, active cutting compound containing a colloid. It melts slowly as frictional heat is generated. It maintains efficient lubrication throughout operations such as pipe screwing, hack sawing, tapping, reaming, etc. It is suitable for all users of hand tools. Trefolex prolongs the life of the tool. It will not corrode steel nor affect aluminium. Although the surface of copper and brass is darkened, the metal suffers no detrimental affect. It is ideal for use with stainless steel and provides excellent finishes.





LONG SERIES DRILLS

High Speed Steel



Long Series drills are longer in flute length and overall length than standard drill bits. They are used for drilling deep holes or in locations which cannot be reached with standard length drill bits.

CODE	DIA MM		OVERALL LENGTH MM		FLUTE LENGTH MM		
METRIC							
LSD2	2.0		108		57		
LSD25	2.5		117		64		
LSD3	3.0		130		70		
LSD35	3.5		137		76		
LSD4	4.0		146		86		
LSD45	4.5		146		86		
LSD5	5.0		152		92		
LSD55	5.5		152		92		
LSD6	6.0		156		95		
LSD65	6.5		159		98		
LSD7	7.0		159		98		
LSD75	7.5		162		102		
LSD8	8.0		165		105		
LSD85	8.5		165		105		
LSD9	9.0		171		105		
LSD95	9.5		171		105		
LSD10	10.0		178		111		
LSD105	10.5		184		117		
LSD11	11.0		184		117		
LSD12	12.0		197		121		
LSD13	13.0		197		121		

CODE	DIA INCH	DIA MM	OVERALL LENGTH MM		FLUTE LENGTH MM		
IMPERIAL							
LSD116	1/16	1.59	76		44		
LSD564	5/64	1.98	95		51		
LSD332	3/32	2.38	117		57		
LSD764	7/64	2.78	130		64		
LSD18	1/8	3.18	137		70		
LSD964	9/64	3.57	137		76		
LSD532	5/32	3.97	137		76		
LSD1164	11/64	4.37	146		86		
LSD316	3/16	4.76	152		92		
LSD1364	13/64	5.16	152		92		
LSD732	7/32	5.56	152		92		
LSD14	1/4	6.35	156		95		
LSD932	9/32	7.14	159		98		
LSD516	5/16	7.94	162		102		
LSD1132	11/32	8.73	165		105		
LSD38	3/8	9.52	171		108		
LSD1332	13/32	10.32	178		111		
LSD716	7/16	11.11	184		117		
LSD1532	15/32	11.91	184		117		
LSD12	1/2	12.7	197		121		



HOLESAWS - BI-METAL

CODE	DIA INCH	DIA MM
HS14	9/16	14.00
HS16	5/8	16.00
HS17	11/16	17.00
HS19	3/4	19.00
HS20		20.00
HS21	13/16	21.00
HS22	7/8	22.00
HS24	15/16	24.00
HS25	1	25.00
HS27	1-1/16	27.00
HS29	1-1/8	29.00
HS30	1-3/16	30.00
HS32	1-1/4	32.00
HS33	1-5/16	33.00
HS35	1-3/8	35.00
HS37	1-7/16	37.00
HS38	1-1/2	38.00
HS40	1-9/16	40.00
HS41	1-5/8	41.00
HS43	1-11/16	43.00
HS44	1-3/4	44.00
HS45		45.00
HS46	1-13/16	46.00
HS48	1-7/8	48.00
HS50		50.00
HS51	2	51.00
HS52	2-1/16	52.00
HS54	2-1/8	54.00
HS55		55.00
HS57	2-1/4	57.00
HS59	2-5/16	59.00
HS60	2-3/8	60.00
HS64	2-1/2	64.00
HS65	2-9/16	65.00
HS67	2-5/8	67.00
HS68		68.00
HS70	2-3/4	70.00
HS73	2-7/8	73.00
HS75		75.00
HS76	3	76.00
HS79	3-1/8	79.00
HS83	3-1/4	83.00
HS86	3-3/8	86.00
HS89	3-1/2	89.00
HS92	3-5/8	92.00
HS95	3-3/4	95.00
HS98	3-7/8	98.00
HS100		100.00
HS102	4	102.00
HS105	4.1/8	105.00
HS108	4.1/4	108.00
HS111	4-3/8	111.00
HS114	4-1/2	114.00
HS121	4-3/4	121.00
HS127	5	127.00
HS140	5-1/2	140.00
HS146	5-3/4	146.00
HS152	6	152.00



OTHER HOLESAWS
AVAILABLE

Tungsten Carbide



Diamond



Carbide Sheetmetal
Cutters



HOLESAW ARBORS & ACCESSORIES



HSA5519



HSA5546



HSP8534



CODE	BORDO CODE	Fits Holesaws	Shank Type	Description
HSA5519	5519	14 - 30mm	3/8 HEX	Fits 3/8" and 1/2" drills
HSA5546	5546	32 - 152mm	11/32 HEX Screw in pins	
PILOT DRILLS				
HSP8534	7060-8534		1/4X3.1/2	89X6.35mm
HSP8535	7060-8535		1/4X4.1/2	114X6.35mm

STEP DRILLS



CODE	DIA METRIC	INCREMENT MM	SHANK DIA	STEPS
STEPDRILL4-12	4 - 12	1	6.0	9
STEPDRILL4-20	4 - 20	2	8.0	9
STEPDRILL6-30	6 - 30	2	10.0	13

QUICKBIT STEP DRILL



STEPDRILL4-25QU	4 - 25	2	1/4 Hex	11
-----------------	--------	---	---------	----

COUNTERSINK HSS-Co5 - 90°

Cross hole countersinks can be used on alloy steels, stainless steel, and other abrasive or difficult materials.







3840-10	10.0			
3840-15	15.0			



CYLINDRICAL BURRS - TUNGSTEN CARBIDE

1/4" SHANK DIA



CODE	HEAD DIA INCH	FLUTE INCH	OAL INCH	OLD CODE	PACK QTY
Cylindrical with end cut 					
SB-3DC	3/8	3/4	2-3/4	6400-95042	1
SB-5DC	1/2	1	3	6400-95048	1
Cylindrical Ball Nose 					
SC-3DC	3/8	3/4	2-3/4	6400-95065	1
SC-5DC	1/2	1	3	6400-95072	1
Tree Radius Nose 					
SF-1DC	1/4	3/4	2	6400-95085	1
SF-3DC	3/8	3/4	2-3/4	6400-95092	1
SF-5DC	1/2	1	3	6400-95100	1
Flame 					
SH-2DC	5/16	3/4	2-3/4	6400-95221	1
SH-5DC	1/2	1-1/4	3-1/4	6400-95225	1
Tree Radius Nose - Aluminium Cut 					
SF-3AL	3/8	3/4	2-3/4	6401-95297	1

SCREW EXTRACTORS

CODE	EXTRACTOR	DRILL SIZE	FOR BOLT SIZE	PACK QTY
SE1	No.1	2.0mm	M4-M5 5/32-3/16	1
SE2	No.2	3.0mm	M6-M8 7/32-1/4	1
SE3	No.3	4.0mm	M8-M10 5/16-3/8	1
SE4	No.4	5.5mm	M10-M14 3/8-1/2	1
SE5	No.5	7.0mm	M14-M20 9/16-3/4	1



Screw Extractor Sets

CODE	EXTRACTORS INCLUDED	PIECES
S15	No.1 - No.5	5
S15A	No.1 - No.6	6
S20	No.1 - No.5 screw ext. Combination drill set	10
	includes jobber drills: 2.0,3.0,4.0,5.5,7.5mm	



S15



S15A



S20

ISO HSS THREADING TAPS

THREAD SIZE	TAPPING DRILL SIZE	PACK QTY	CODE TAPER	CODE INTER	CODE BOTT	
METRIC COARSE						
M3 X 0.5	2.5	1	T3840300	T3850300	T3860300	
M4 X 0.7	3.3	1	T3840400	T3850400	T3860400	
M5 X 0.8	4.2	1	T3840500	T3850500	T3860500	
M6 X 1.0	5.0	1	T3840600	T3850600	T3860600	
M8 X 1.25	6.8	1	T3840800	T3850800	T3860800	
M10 X 1.5	8.5	1	T3841000	T3851000	T3861000	
M12 X 1.75	10.2	1	T3841200	T3851200	T3861200	
M14X 2.0	12.0	1	T3841400	T3851400	T3861400	
M16 X 2.0	14.0	1	T3841600	T3851600	T3861600	
M20 X 2.5	17.5	1	T3842000	T3852000	T3862000	
METRIC FINE						
M10 X 1.25	8.8	1	T4011006	T4021006	T4031006	
M12 X 1.25	10.8	1	T4011206	T4021206	T4031206	
M12X1.5	10.5	1	T4011207	T4021207	T4031207	
M14X1.5	12.5	1	T4011407	T4021407	T4031407	
M16X1.5	14.5	1	T4011607	T4021607	T4031607	
BSW						
1/8 X 40	2.55	1	T4510318	T4520318	T4530318	
5/32 X 32	3.2	1	T4510397	T4520397	T4530397	
3/16 X 24	3.7	1	T4510476	T4520476	T4530476	
1/4 X 20	5.1	1	T4510635	T4520635	T4530635	
3/8 X 16	7.9	1	T4510953	T4520953	T4530953	
UNC						
8X32	3.4	1	T4140417	T4150417	T4160417	
10X24	3.8	1	T4140483	T4150483	T4160483	
1/4X20	5.1	1	T4140635	T4150635	T4160635	
5/16X18	6.6	1	T4140794	T4150794	T4160794	
3/8 X 16	8.0	1	T4140953	T4150953	T4160953	
7/16X14	9.4	1	T4141111	T4151111	T4161111	
1/2X13	10.8	1	T4141270	T4151270	T4161270	
5/8X11	13.5	1	T4141588	T4151588	T4161588	
3/4X10	16.5	1	T4141905	T4151905	T4161905	
UNF						
8X36	3.5	1	T4310417	T4320417	T4330417	
10X32	4.1	1	T4130483	T4320483	T4330483	
1/4X28	5.5	1	T4130635	T4320635	T4330635	
5/16X24	6.9	1	T4130794	T4320794	T4330794	
3/8 X 24	8.5	1	T4130953	T4320953	T4330953	
7/16X20	9.8	1	T4131111	T4321111	T4331111	
1/2X20	11.5	1	T4131270	T4321270	T4331270	
5/8X18	14.5	1	T4131588	T4321588	T4331588	
3/4X16	17.5	1	T4131905	T4321905	T4331905	



DIES CARBON



BUTTON DIES

METRIC - COARSE

CODE	SIZE	OD	
M400 0300	M3 X 0.5	1"	
M400 0400	M4 X 0.7	1"	
M400 0500	M5 X 0.8	1"	
M400 0600	M6 X 1.0	1"	
M400 0800	M8 X 1.25	1"	
M400 1000	M10 X 1.5	1"	
M400 1200	M12 X 1.75	1"	
M402 1600	M16 X 2.0	2"	
M402 2000	M20 X 2.5	2"	

UNC

CODE	SIZE	OD	
M412 0635	1/4 X 20	1"	
M412 0794	5/16 X 18	1"	
M412 0953	3/8 X 16	1"	
M412 1111	7/16 X 14	1"	
M412 1270	1/2 X 13	1"	

METRIC - FINE

CODE	SIZE	PACK QTY	
M403 0805	M8X1.0	1"	
M403 1006	M10X1.25	1"	
M403 1206	M12X1.25	1"	
M403 1207	M12X1.5	1"	
M405 1607	M16X1.5	2"	
M405 2007	M20X1.5	2"	

UNF

CODE	SIZE	PACK QTY	
M415 0635	1/4X28	1"	
M415 0794	5/16X24	1"	
M415 0953	3/8X24	1"	
M415 1111	7/16X20	1"	
M415 1270	1/2X20	1"	

DIENUTS



METRIC - COARSE

CODE	SIZE		
M440 0500	M5 X 0.8		
M440 0600	M6 X 1.0		
M440 0800	M8 X 1.25		
M440 1000	M10 X 1.5		
M440 1200	M12 X 1.75		
M440 1600	M16 X 2.0		
M402 2000	M20 X 2.5		
M440 2400	M24 X 3.0		

UNC

CODE	SIZE	OD	
M445 0635	1/4X20		
M445 0794	5/16X18		
M445 0953	3/8X16		
M445 1111	7/16X14		
M445 1270	1/2X13		
M445 1588	5/8X11		
M445 1905	3/4X10		

UNF

CODE	SIZE	OD	
M445 0635	1/4X28		
M445 0794	5/16X24		
M445 0953	3/8X24		
M445 1111	7/16X20		
M445 1270	1/2X20		
M445 1588	5/8X18		

BAR TYPE TAP WRENCH

CODE	CAPACITY	PACK QTY	
TWB0	3.0 - 10.00	1	
TWB5	5.0 - 16.0	1	

BUTTON DIE HOLDERS

CODE	CAPACITY	PACK QTY	
BDH1	1"	1	
BDH2	2"	1	

TAP WRENCHES

T PATTERN

CODE	RANGE	PACK QTY	
TWT6	M3 - M6	1	
TWT12	M6 - M12	1	



ABRASIVE WHEELS



CODE	SIZE MM INCH	MAX R.P.M	PACK QTY	SUPPLIER PRODUCT CODE
FLAT METAL CUTTING WHEELS				
MCOW100	100X2.5X16	15300	100	1010216
MCOW115	115X2.5X22	13330	100	1011522
MCOW125	125X2.5X22	12250	100	1012722
MCOW230	230X2.5X22	6650	50	1023022
MCOW230K	230X2.5X22 Klingspor	6650	50	123833
MCOW230X25	230X2.5X25.4	6650	50	1023025
MCOW300X25	300X3.0X25.4	5100	20	1930525
MCOW350	350X3.0X25.4	4400	20	1935625
MEGA INOX ULTRA THIN - FLEXOVIT				
MCOWT75	75X1.0X10	20,370	20	GCDGX07510
MCOWT100	100X1.0X16	15300	100	15102010
MCOWT115	115X1.0X22	13330	100	15115010
MCOWT125	125X1.0X22	12250	100	15127010
MCOWT230	230X2X22	6650	50	15230020
ULTRA THIN - KLINGSPOR				
MCOWT100K	100X1.0X16	15300	100	202402
MCOWT115K	115X1.0X22	13330	100	202400
MCOWT125K	125X1.0X22	12250	100	202401
FLAT ALUMINIUM CUTTING WHEELS				
ACOW230	230X2.5X22	6650	50	1623022
BENCH GRINDING WHEELS - ALUM OXIDE				
BV173592	150X25XMULTI BORE	A46MV	EA	Medium
BV173606	150X25XMULTI BORE	A60MV	EA	Fine
BV114847	200X25X31.75	38A46KVB	EA	Coarse
METAL DEPRESSED CENTRE GRINDING WHEELS				
MGW100	100 X 6.0 X 16	15300	50	6310260
MGW115	115 X 6.0 X 22	13300	50	6311560
MGW125	125 X 6.8 X 22	12250	50	6012768
MGW230	230 X 6.8 X 22	6800	10	6023068
ULTRA THIN MULTI MATERIAL GRINDING WHEELS				
Suitable for a variety off materials including Masonry, Stainless, Metal, Aluminium, Pvc, and Ceramic.				
MGW125MULTI	125 X 22.2	12,250	10	





FIBRE DISC
PREMIUM QUALITY

CODE	DESCRIPTION	KLINGSPOR TYPE	PACK QTY	KLINGSPOR CODE
TYPE CS561 - GRAIN Aluminium Oxide				
Applications: Steel, NF Metals, Metals				
100mm X 16mm				
FD100X36	100 X 16 X 36GRIT	CS561	25	65718
FD100X60	100 X 16 X 60GRIT	CS561	25	65730
FD100X120	100 X 16 X 120GRIT	CS561	25	65743
115mm X 22mm				
FD115X60	115 X 22 X 60GRIT	CS561	25	10983
FD115X80	115 X 22 X 80GRIT	CS561	25	10984
FD115X120	115 X 22 X 120GRIT	CS561	25	10986
125mm X 22mm				
FD125X36	125 X 22 X 36GRIT	CS561	25	11012
FD125X60	125 X 22 X 60GRIT	CS561	25	11015
FD125X80	125 X 22 X 80GRIT	CS561	25	11016
180mm X 22mm				
FD180X60	180 X 22 X 60GRIT	CS561	25	11063
TYPE CS565 - GRAIN Zirconia Alumina				
Applications: Steel, Metals, Stainless Steel				
100mm X 16mm				
FD100X36K	100 X 16 X 36GRIT	CS565	25	23680
115mm X 22mm				
FD115X36K	115 X 22 X 36GRIT	CS565	25	6686
FD115X60K	115 X 22 X 60GRIT	CS565	25	6687
125mm X 22mm				
FD125X60K	125 X 22 X 60GRIT	CS565	25	6721
FD125X36K	125 X 22 X 36GRIT	CS565	25	6620
180mm X 22mm				
FD180X36K	180 X 22 X 36GRIT	CS565	25	65703
FD180X60K	180 X 22 X 60GRIT	CS565	25	6690
TYPE CS570 Multibond - GRAIN Zirconia Alumina				
Applications: Stainless Steel, Aluminium				
125mm X 22mm				
FD125X80KM	125 X 22 X 80GRIT	CS570	25	204096
TYPE FS964 ACT - GRAIN Ceramic Al Oxide				
Applications: Steel, Stainless Steel				
125mm X 22mm				
FD125X80CFS964	125 X 22 X 80GRIT	FS964ACT	25	330490
TYPE FS966 ACT - GRAIN Ceramic				
Applications: Stainless Steel				
125mm X 22mm				
FD125X36CERAMIC	125 X 22 X 36GRIT	FS966 ACT	25	316494
180mm X 22mm				
FD180X36CERAMIC	180 X 22 X 36GRIT	FS966 ACT	25	316498

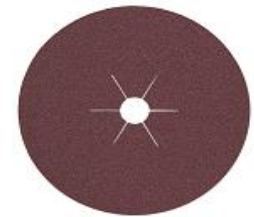

CS561

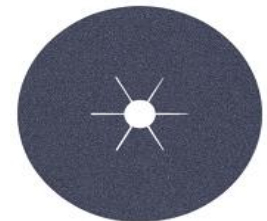

CS565

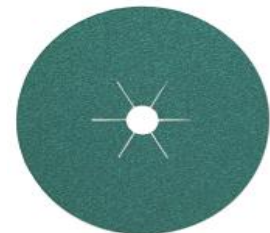

CS570



FS964 ACT

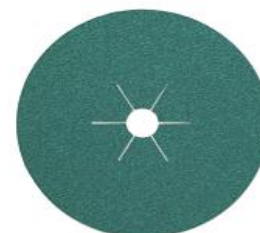

FS966 ACT

FIBRE DISC BACKING PADS



CODE	DESCRIPTION	PACK QTY
AM991001	102MM M10X1.50	1
AM097463	102MM M10X1.25	1
AM991027	115MM M14X2.00	1
AM991040	125MM M14X2.00	1
AM991053	178MM M14X2.00	1



FLAP DISC - POLIFANS

Gold Series

Premium 100% Zirconia abrasive



CODE	DESCRIPTION	PACK QTY
GFDGS10040	100 X 16 X 40G ZIRCONIA	10
GFDGS10060	100 X 16 X 60G ZIRCONIA	10
GFDGS10080	100 X 16 X 80G ZIRCONIA	10
GFDGS10120	100 X 16 X 120G ZIRCONIA	10
GFDGS11540	115 X 22 X 40G ZIRCONIA	10
GFDGS11560	115 X 22 X 60G ZIRCONIA	10
GFDGS11580	115 X 22 X 80G ZIRCONIA	10
GFDGS115120	115 X 22 X 120G ZIRCONIA	10
GFDGS12540	125 X 22 X 40G ZIRCONIA	10
GFDGS12560	125 X 22 X 60G ZIRCONIA	10
GFDGS12580	125 X 22 X 80G ZIRCONIA	10
GSPD125BC	125mm Surface Preparation Clean & Strip Disc Black	10
GFDS17840	178 X 22 X 40G ZIRCONIA	10



PORTABLE BELTS

ALUMINIUM OXIDE



CODE	DESCRIPTION	PACK QTY	KLINGSPOR CODE
BELT75X533X80	75MM X 533MM X 80G	10	321365
BELT75X533X100	75MM X 533MM X 100G	10	321266
CF192473	100MM X 610MM X 40G	10	321273
CF177768	100MM X 610MM X 60G	10	321274
CF171522	100MM X 610MM X 80G	10	321275
CF166235	100MM X 610MM X 100G	10	321276
CF161322	100MM X 610MM X 120G	10	321277



PORTABLE BELTS

PURE ZIRCONIA

CODE	DESCRIPTION	PACK QTY	KLINGSPOR CODE
BELT10X330X40G	10MM X 330MM X 40G	10	318648
BELT20X520X40	20MM X 520MM X 40G	10	318649
BELT20X520X60	20MM X 520MM X 60G	10	307973
BELT20X520X120G	20MM X 520MM X 120G	10	318650
BELT50X915X36G	50MM X 915MM X 36G	10	





SANDPAPER ROLLS

Aluminium Oxide

CODE	DESCRIPTION		PACK QTY	KLINGSPOR CODE
CE354783	115MM X 50M X 60G	Coarse	1	155815
CE862883	115MM X 50M X 120G	Medium	1	153398
CE863013	115MM X 50M X 180G	Fine	1	149480
CE863130	115MM X 50M X 240G	Very Fine	1	147055
CE863208	115MM X 50M X 320G	Very Fine	1	148891



SANDPAPER SHEETS

Aluminium Oxide

CODE	DESCRIPTION		PACK QTY	KLINGSPOR CODE
SANDPA23028080	230MM X 280M X 80G	Coarse	1	320686
SANDPA230280100	230MM X 280M X 100G	Coarse	1	320687
SANDPA230280120	230MM X 280M X 120G	Medium	1	320688
SANDPA230280150	230MM X 280M X 150G	Medium	1	320689
SANDPA230280180	230MM X 280M X 180G	Fine	1	320690
SANDPA230280240	230MM X 280M X 240G	Very Fine	1	320691



SPEED GRIP VELGRIP DISC

Aluminium Oxide

CODE	DESCRIPTION		PACK QTY	KLINGSPOR CODE
CD858203	125X8Hole Grit 40		50	89486
CD858411	125X8Hole Grit 80		50	89489
CD858554	125X8Hole Grit 120		50	89493
CD858775	125X8Hole Grit 240		50	92753



INDUSTRIAL WIRE BRUSHES

CODE	DESCRIPTION		OTHER CODE
ARBOR OR THREAD HOLE BRUSHES			
W3340BP	75mm Twist Knot Cup M14-2.0		5100-70-3.5
W3400	100mm Twist Knot Cup M14		5100-100-3.5
W2940BP	75mm Crimped Cup M14-2.0		5104-75-3.3
W4220BP	100mm Bevelled Twist M10-1.5		5112-100-2.5
BENCH WHEEL BRUSHES			
W2420	200mm x 28 x Multi Bore (Includes plastic bushing)		5108-200/28.3





DIAMOND SAW BLADES

Suitable for: Concrete/Reinforced, Clay Bricks, Terracotta Roof Tiles, Granite, Bluestone, Steel Pipe/Tube & Hebel Block. Wet/Dry use.

CODE	SIZE		MAX R.P.M	PACK QTY	SUPPLIER PRODUCT CODE
	MM	INCH			
RAPTOR Turbo Rim Blades					
DCOW105	105 X 16/20/22		IT100		
DCOW115	115 X 22.2		IT115		
DCOW125	125 X 22.2		IT125		
DCOW230	230 X 22.2/25.4		IT230		
RAPTOR Turbo Rim Thin Series Blades					
Suitable for: Porcelain Tiles, Marble, Granite, Vitrified Tiles, Glazed Tiles, Slate					
ITT100	105 X 16/20/22		ITT100		
ITT125	125 X 22.2		ITT125		



Austsaw - 185mm (7in) Rotary Hacksaw Blade 20/16mm Bore - 36 Teeth

Designed for **CUTTING**

Fibreglass

Metal, Aluminium, Colorbond, Steel (Guardrail, Pipes), Iron (Corrugated, Pipes)

Plastic (PVC Plastic / Pipes, Corrugated Roofing)

Wood (Softwoods, Hardwoods, Timber Planks, Weather Board).



EXTREME performance

The Austsaw Rotary Hacksaw cutting blade is made with a hardened tempered body for clean, smooth cuts (fast and smooth cutting action). Titanium carbide teeth provide longer life when metal cutting, and a high-raised shoulder provides maximum strength behind each tip.

Purchase the Austsaw Rotary Hacksaw circular saw blade and you will experience extreme cutting performance!

CODE	DESCRIPTION	TEETH	PACK QTY	AUSTSAW CODE
SAWBLADEM18536T	7"(185MM) X 20/16MM	36	1	RHS185201636

FILES WITH HANDLES - Nicholson

Nicholson®

FH200	Handy File 200mm	T06601
FF2250	FLAT Second Cut 250MM With Handle	903699AU



BSW MILD 4.6 STEEL HEX HEAD BOLTS AND NUTS ZINC PLATED



List Price Per 100

DIAMETER	1/4"	5/16"	3/8"	1/2"
LENGTH				
3/4	✓	✓	✓	
1	✓	✓	✓	✓
1.1/4	✓	✓	✓	✓
1.1/2	✓	✓	✓	✓
1.3/4	✓	✓	✓	✓
2	✓	✓	✓	✓
2.1/4	✓	✓	✓	✓
2.1/2	✓	✓	✓	✓
3	✓	✓	✓	✓
3.1/2	✓	✓	✓	✓
4	✓	✓	✓	✓
4.1/2	✓	✓	✓	✓
5	✓	✓	✓	✓
6	✓	✓	✓	✓

BSW CLASS 4.6 HEX SET SCREWS ZINC PLATED



List Price Per 100

DIAMETER	1/4"	5/16"	3/8"	1/2"	5/8"
LENGTH					
1/2	✓	✓			
3/4	✓	✓	✓	✓	
1	✓	✓	✓	✓	
1.1/4	✓	✓	✓	✓	
1.1/2	✓	✓	✓	✓	✓
2	✓	✓	✓	✓	✓
2.1/2	✓	✓	✓	✓	✓
3	✓	✓	✓	✓	✓
3.1/2			✓		
4			✓	✓	✓

METRIC CLASS 4.6 PURLIN BOLTS & NUTS ZINC PLATED



List Price Per 100

Purlin Bolt Assembly With 2 Washers			Purlin Bolt Flanged		
DIAMETER	M12	CODE	DIAMETER	M12	CODE
LENGTH			LENGTH		
30	✓	PURLINBOLT1230	30	✓	PURLINFLAN1230

METRIC CLASS 4.6 HEX HEAD BOLTS & NUTS ZINC PLATED



List Price Per 100

DIAMETER	M6-1.0	M8-1.25	M10-1.5	M12-1.75	M16-2.0	M20-2.50
LENGTH						
MM						
20	✓	✓	✓			
25	✓	✓	✓	✓	✓	
30	✓	✓	✓	✓	✓	
35	✓	✓	✓	✓	✓	✓
40	✓	✓	✓	✓	✓	✓
45	✓	✓	✓	✓	✓	✓
50	✓	✓	✓	✓	✓	✓
55	✓	✓	✓	✓	✓	✓
60	✓	✓	✓	✓	✓	✓
65	✓	✓	✓	✓	✓	✓
70	✓	✓	✓	✓	✓	✓
75	✓	✓	✓	✓	✓	✓
80	✓	✓	✓	✓	✓	✓
90	✓	✓	✓	✓	✓	✓
100	✓	✓				
120	✓	✓				
130	✓	✓				
140	✓	✓				
150	✓	✓				

METRIC CLASS 4.6 HEX HEAD SET SCREWS ZINC PLATED - Metric Coarse Thread



List Price Per 100

DIAMETER	M4	M5	M6	M8	M10	M12	M16
LENGTH							
10	✓		✓				
12	✓		✓	✓	✓		
16	✓		✓	✓	✓		
✓	✓		✓	✓	✓	✓	
25	✓		✓	✓	✓	✓	
30	✓		✓	✓	✓	✓	✓
35	✓		✓	✓	✓	✓	✓
✓	✓		✓	✓	✓	✓	✓
50	✓		✓	✓	✓	✓	✓
60			✓	✓	✓	✓	✓
65			✓	✓	✓	✓	✓
75			✓	✓	✓	✓	✓
100				✓	✓	✓	✓

HIGH TENSILE

METRIC COARSE HEX HEAD BOLTS ONLY CLASS 8.8

ZINC PLATED

List Price Per 100



DIAMETER	M6-1.0	M8-1.25	M10-1.5	M12-1.75	M14-2.0	M16-2.0
LENGTH						
MM						
25	✓	✓	✓	✓	✓	✓
30	✓	✓	✓	✓	✓	✓
35	✓	✓	✓	✓		✓
40	✓	✓	✓	✓	✓	✓
45	✓	✓	✓	✓	✓	✓
50	✓	✓	✓	✓	✓	✓
55	✓	✓	✓	✓	✓	✓
60	✓	✓	✓	✓	✓	✓
65	✓	✓	✓	✓	✓	✓
70	✓	✓	✓	✓	✓	✓
75	✓	✓	✓	✓	✓	✓
80	✓	✓	✓	✓	✓	✓
90		✓	✓	✓	✓	✓
100		✓	✓	✓	✓	✓
110		✓	✓	✓		✓
120		✓	✓	✓	✓	✓
130		✓	✓	✓		✓
140			✓	✓		✓

HIGH TENSILE

METRIC HEX HEAD SET SCREWS CLASS 8.8

ZINC PLATED - Metric Coarse Thread

List Price Per 100

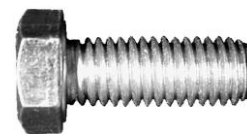

DIAMETER	M6-1.0	M8-1.25	M10-1.5	M12-1.75	M16-2.0
LENGTH					
12	✓	✓			
16	✓	✓	✓		
20	✓	✓	✓	✓	
25	✓	✓	✓	✓	✓
30	✓	✓	✓	✓	✓
35	✓	✓	✓	✓	✓
40	✓	✓	✓	✓	✓
50	✓	✓	✓	✓	✓
60		✓		✓	✓
65		✓	✓	✓	✓
70		✓	✓	✓	✓
75		✓	✓	✓	✓
80			✓	✓	✓
90					✓
100		✓	✓	✓	✓

HIGH TENSILE
METRIC HEX HEAD SET SCREWS/HEX BOLT CLASS 10.9
ZINC PLATED - Metric Coarse Thread



List Price Per 100

SET SCREWS			HEX BOLTS	
DIAMETER	M10-1.5	M12-1.75	DIAMETER	M12-1.25
LENGTH			LENGTH	
25	✓	✓	75	✓
30	✓	✓	90	✓
40	✓	✓	100	✓
75	✓	✓		
90	✓			

HIGH TENSILE
METRIC HEX STRUCTURAL ASSEMBLIES BOLTS, NUTS & WASHERS
GAL - GRADE 8.8



List Price Per 100

DIAMETER	M16-2.0	M20-2.5
LENGTH		
40	✓	✓
45	✓	✓
50	✓	✓
55	✓	✓
60	✓	✓
65	✓	✓
75	✓	✓
80	✓	✓
100	✓	✓
110	✓	✓

HEX COACH SCREWS



List Price Per 100

10mm DIAMETER		
LENGTH	GALV	ZINC
MM		
40	✓	✓
50	✓	✓
65	✓	✓
75	✓	✓
90	✓	✓
100	✓	✓
120	✓	✓
130	✓	✓
150	✓	✓

12mm DIAMETER		
LENGTH	GALV	ZINC
MM		
40	✓	
50	✓	✓
75	✓	✓
90	✓	✓
100	✓	✓
120	✓	
130	✓	✓
150	✓	✓
200	✓	✓

METRIC CUP HEAD BOLTS & NUTS



List Price Per 100

DIAMETER MM	LENGTH MM	THREAD LENGTH	Zinc Plated	Galvanised
6 - 1.0	20	Full	✓	✓
	25	Full	✓	✓
	30	Full	✓	✓
	40	30	✓	✓
	50	30	✓	✓
	60	30	✓	✓
	70	50	✓	✓
	75	50	✓	✓
	90	50	✓	✓
	100	75	✓	✓
8 - 1.25	20	Full	✓	✓
	25	Full	✓	✓
	30	Full	✓	✓
	40	30	✓	✓
	50	30	✓	✓
	60	30	✓	✓
	70	50	✓	✓
	90	50	✓	✓
	100	75	✓	✓
	10 - 1.5	25	Full	✓
30		Full	✓	✓
40		Full	✓	✓
50		40	✓	✓
60		40	✓	✓
70		40	✓	✓
85		60	✓	✓
90		60	✓	✓
100		60	✓	✓
110		80	✓	✓
120		80	✓	✓
130		80	✓	✓
140		80	✓	✓
150		80	✓	✓
160		100		✓
170		100	✓	✓
180		100	✓	✓
200		100	✓	✓
240		100		✓
260		100		✓
300	100		✓	
12 - 1.75	30	Full		✓
	40	Full	✓	✓
	50	40	✓	✓
	65	40	✓	✓
	75	40	✓	✓
	85	60		✓
	90	60	✓	✓
	100	60	✓	✓
	110	80		✓
	120	80		✓
	130	80	✓	✓
	150	80	✓	✓
	160	100		✓
	180	100	✓	✓
	200	100	✓	✓
	220	130		✓
	240	130		✓
	260	130		✓
	280	130		✓
	300	150		✓
400	150		✓	





METAL THREAD SCREWS

ZINC PLATED



Pan



CSK

SAMPLE CODE: MTSC1434 = 1/4X3/4 CSK

SAMPLE CODE: MTSMP620 = M6X20 PAN

DIAMETER BSW	LENGTH		DIAMETER METRIC	LENGTH	
1/8	1/4	✓	M3	10	✓
	3/8	✓		12	✓
	1/2	✓		16	✓
	3/4	✓		20	✓
	1	✓		25	✓
5/32	3/8	✓	M4	6	✓
	1/2	✓		10	✓
	5/8	✓		12	✓
	3/4	✓		16	✓
	1	✓		20	✓
3/16	1/4	✓		25	✓
	3/8	✓		30	✓
	1/2	✓		35	✓
	5/8	✓		40	✓
	3/4	✓		50	✓
	1	✓	M5	10	✓
	1.1/4	✓		16	✓
	1.1/2	✓		20	✓
	1.3/4	✓		25	✓
	2	✓		30	✓
	2.1/2	✓		40	✓
3	✓	50		✓	
1/4	3/8	✓	M6	10	✓
	1/2	✓		12	✓
	5/8	✓		16	✓
	3/4	✓		20	✓
	1	✓		25	✓
	1.1/4	✓		30	✓
	1.1/2	✓		40	✓
	2	✓		50	✓
	2.1/2	✓		65	✓
	3	✓		75	✓
			M8	16	✓
				25	✓
				50	✓
			M10	25	✓
				50	✓

ARS Bolt,Rivet Nut & Washer
For Truck FRP panel and
Hardware.



RB5161CL	5/16 X 1 Roof Bolt Comb With Loctite	✓
3060	5/16 Rivet Nuts Z/Y	✓
WFM112302	11.2X30.0X2.0MM Round Washer Z/F	✓



ROOFING BOLTS ZINC PLATED - Imperial

SAMPLE CODE: RB31634

DIAMETER BSW	LENGTH	
3/16	3/8	✓
	1/2	✓
	3/4	✓
	1	✓
	1.1/4	✓
	1.1/2	✓
	2	✓
	3	✓
1/4	1/2	✓
	3/4	✓
	1	✓
	1.1/4	✓
	1.1/2	✓
	1.3/4	✓
	2	✓
	2.1/2	✓
5/16	3/4	✓
	1	✓
	1.1/4	✓
	2	✓
	2.1/2	✓
	3	✓



HANDLE SCREWS ZINC PLATED

SAMPLE CODE: MTSM420

DIAMETER	LENGTH	
M4	16	✓
	20	✓
	22	✓
	28	✓
	35	✓
	40	✓

ROOFING BOLTS

ZINC PLATED - Metric

SAMPLE CODE: RBM616C

DIAMETER MM	LENGTH MM	
6.0	16	✓
	25	✓
	30	✓
	40	✓

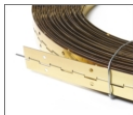

PIANO HINGE

DESCRIPTION	CODE	
Continuous Butt Hinge 32mmx0.7x25m Roll Nickel Plated		
 PIANOHINGENP25		✓
Continuous Butt Hinge Drilled 32mmx1.2x1.8m Length 304 Stainless		
	PIANOHINGESS32	✓

NUTS - TEE FOR WOOD 4 PRONG ZINC PLATED

CODE	SIZE X BARREL LTH	BOX QTY	
BSW			
TN316	18mm X 7.0mm	1000	✓
TN14	18mm X 7.0mm	1000	✓
TN516	22MM X 9.0mm	1000	✓
TN511658	22mm X 16MM	1000	✓
TN38	25mm X 11MM	1000	✓
METRIC			
TN4	15mm X 7.0mm	1000	✓
TN5	15mm X 7.0mm	1000	✓
TN6	18MM X 7.0mm	1000	✓
TN8	22mm X 9.0MM	1000	✓
TN8L	22mm X 16MM	1000	✓
TN10	25mm X 11MM	1000	✓





NUTS - HEXAGON

ZINC PLATED

BSW CODE	SIZE			METRIC CODE	SIZE	
HNB18	1/8	✓		HN3	M3	✓
HNB532	5/32	✓		HN4	M4	✓
HNB316	3/16	✓		HN5	M5	✓
HNB14	1/4	✓		HN6	M6	✓
HNB516	5/16	✓		HN8	M8	✓
HNB38	3/8	✓		HN10	M10	✓
HNB12	1/2	✓		HN12	M12	✓
HNB58	5/8	✓		HN16	M16	✓
HNB34	3/4	✓		HN20	M20	✓



NUTS - NYLON INSERT

LOCK NUTS

SIZE						
	UNC	UNF	METRIC	CLASS6	CLASS8	CLASS10
3/16	✓		M3	✓	✓	
1/4	✓	✓	M4	✓	✓	
5/16	✓	✓	M5	✓	✓	
3/8	✓	✓	M6	✓	✓	
7/16	✓		M8	✓	✓	✓
1/2	✓	✓	M10	✓	✓	✓
9/16	N/A	✓	M12	✓	✓	✓
5/8	✓	✓	M16	✓	✓	✓
3/4	✓	✓	M20	✓	✓	✓
7/8	✓	✓	M24	✓	✓	✓
1	✓	POA				



NUTS - DOME

BRASS - NICKEL PLATED

STAINLESS STEEL 304

BSW CODE	SIZE			METRIC CODE	SIZE	
DNB18	1/8	✓		DNSS4	M4	✓
DNB532	5/32	✓		DNSS5	M5	✓
DNB316	3/16	✓		DNSS6	M6	✓
DNB14	1/4	✓		DNSS8	M8	✓
DNB516	5/16	✓		DNSS10	M10	✓
DNB38	3/8	✓		DNSS12	M12	✓



NUTS - WING

STEEL - ZINC PLATED

FLANGE SERRATED LOCKING

STEEL - ZINC PLATED - CLASS 8

CODE	SIZE			METRIC CODE	SIZE	
WNB14	1/4 BSW	✓		HNF4	M4	✓
WN6	M6	✓		HNF5	M5	✓
WN8	M8	✓		HNF6	M6	✓
WN10	M10	✓		HNF8	M8	✓
WN12	M12	✓		HNF10	M10	✓

METAL THREAD SCREWS PAN & CSK HEAD - Phillips Recess 304 Stainless



CODE	SIZE	FINISH	PACK QTY	
CSK=MTSCSS				
MTSPSS416	M4X16	304	100	✓
MTSPSS420	M4X20	304	100	✓
MTSPSS425	M4X25	304	100	✓
MTSPSS430	M4X30	304	100	✓
MTSPSS612	M6X12	304	100	✓
MTSPSS616	M6X16	304	100	✓
MTSPSS620	M6X20	304	100	✓
MTSPSS625	M6X25	304	100	✓
MTSPSS630	M6X30	304	100	✓
MTSPSS640	M6X40	304	100	✓
MTSPSS650	M6X50	304	100	✓
MTSPSS820	M8X20	304	100	✓
MTSPSS825	M8X25	304	100	✓
MTSPSS830	M8X30	304	100	✓
MTSPSS840	M8X40	304	100	✓
MTSPSS850	M8X50	304	100	✓



*Also available in imperial sizing

HEX HEAD SET SCREWS & BOLTS - 304 Stainless

HEX SET SCREW

CODE	SIZE	
SSSS620	M6X20	✓
SSSS625	M6X25	✓
SSSS630	M6X30	✓
SSSS635	M6X35	✓
SSSS640	M6X40	✓
SSSS645	M6X45	✓
SSSS650	M6X50	✓
SSSS816	M8X16	✓
SSSS820	M8X20	✓
SSSS825	M8X25	✓
SSSS830	M8X30	✓
SSSS840	M8X40	✓
SSSS850	M8X50	✓
SSSS1035	M10X20	✓
SSSS1040	M10X25	✓
SSSS1035	M10X35	✓
SSSS1040	M10X40	✓
SSSS1045	M10X45	✓
SSSS1050	M10X50	✓
SSSS1060	M10X60	✓
SSSS1070	M10X70	✓
SSSS1080	M10X80	✓
SSSS1240	M12X25	✓
SSSS1250	M12X40	✓
SSSS1260	M12X50	✓

HEX BOLT

CODE	SIZE	
XOSSM640	M6X40	✓
XOSSM645	M6X45	✓
XOSSM650	M6X50	✓
XOSSM660	M6X60	✓
XOSSM670	M6X70	✓
XOSSM680	M6X80	✓
XOSSM840	M8X40	✓
XOSSM845	M8X45	✓
XOSSM850	M8X50	✓
XOSSM860	M8X60	✓
XOSSM870	M8X70	✓
XOSSM880	M8X80	✓
XOSSM1040	M10X40	✓
XOSSM1045	M10X45	✓
XOSSM1050	M10X50	✓
XOSSM1060	M10X60	✓
XOSSM1070	M10X70	✓
XOSSM1080	M10X80	✓
XOSSM1090	M10X90	✓
XOSSM10100	M10X100	✓
XOSSM1240	M12X40	✓
XOSSM1250	M12X50	✓
XOSSM1260	M12X60	✓
XOSSM1270	M12X70	✓
XOSSM1280	M12X80	✓

Hex nuts Imperial & Metric - 304 Stainless

UNC CODE	SIZE			METRIC CODE	SIZE	
HNSSUNC14	1/4	✓		HNSS3	M3	✓
HNSSUNC516	5/16	✓		HNSS4	M4	✓
HNSSUNC38	3/8	✓		HNSS5	M5	✓
HNSSUNC12	1/2	✓		HNSS6	M6	✓
HNSSUNC58	5/8	✓		HNSS8	M8	✓
HNSSUNC34	3/4	✓		HNSS10	M10	✓
				HNSS12	M12	✓
*UNF also available			HNSS16	M16	✓	
			HNSS20	M20	✓	

Nyloc Hex nuts Imperial & Metric - 304 Stainless

UNC CODE	SIZE			METRIC CODE	SIZE	
NNSSUNC14	1/4	✓		NNSS3	M3	✓
NNSSUNC516	5/16	✓		NNSS4	M4	✓
NNSSUNC38	3/8	✓		NNSS5	M5	✓
NNSSUNC12	1/2	✓		NNSS6	M6	✓
NNSSUNC58	5/8	✓		NNSS8	M8	✓
NNSSUNC34	3/4	✓		NNSS10	M10	✓
				NNSS12	M12	✓
*UNF also available			NNSS16	M16	✓	
			NNSS20	M20	✓	

Flat Washers Imperial & Metric - 304 Stainless

IMPERIAL CODE	SIZE			METRIC CODE	SIZE	
WFSS31671620	3/16X7/16X20	✓		WFSS4908	M4X9X0.8	✓
WFSS3161220	3/16X12X20	✓		WFSS51008	M5X10X0.8	✓
WFSS3163418	3/16X3/4X18	✓		WFSS61212	M6X12X1.2	✓
WFSS141220	1/4X12X20	✓		WFSS61816	M6X18X1.6	✓
WFSS143418	1/4X3/4X18	✓		WFSS81712	M8X17X1.2	✓
WFSS141116	1/4X1X16	✓		WFSS102112	M10X21X1.2	✓
WFSS1411416	1/4X1-1/4X16	✓		WFSS122416	M12X24X1.6	✓
WFSS383418	3/8X3/4X18	✓				
WFSS381116	3/8X1X16	✓				
WFSS3411214	3/4X1-1/2X14	✓				

Not all stainless sizes available are listed in our catalogue, for further enquiries please give us a call.

THREADED ROD

MILD STEEL ZINC PLATED



SIZE METRIC	FINISH	PACK SIZE	LGTH 1 METRE	LGTH 3 METRE	CODE Add 1 to end code or 3 lgth
M6	Zinc Plated	20	✓	✓	TR6
M8	Zinc Plated	20	✓	✓	TR8
M10	Zinc Plated	20	✓	✓	TR10
M10	Galvanised	20	✓	✓	TR103G
M12	Zinc Plated	10	✓	✓	TR12
M16	Zinc Plated	10	✓	✓	TR16
M20	Zinc Plated	5	✓	✓	TR20

HEX COUPLING NUT

MILD STEEL CL5 ZINC PLATED



METRIC SIZE	CODE	PACK SIZE	LENGTH MM	
M6	HC6	500	25	✓
M8	HC8	500	24	✓
M10	HC10	250	30	✓
M12	HC12	250	36	✓
M16	HC16	100	50	✓

PURLIN CLAMP

MILD STEEL ZINC PLATED

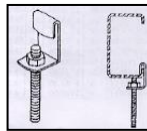

M10 METRIC	PCM10			✓
------------	-------	--	--	---



THREADED ROD CUTTER

M10	NKM10	EA		✓
SPARE JAWS				
For M10	NKS10	EA		✓

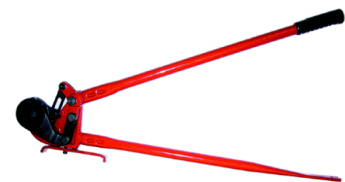

CODE	DESCRIPTION	BOX QTY	
HS30/30	Holistrap 30mm x 30mtr x 0.8mm Roll	EA	✓
FOILFAST	Foil & Shade Cloth Fastener 50 Strips of 10-23x25mm 4 Pin	500	✓

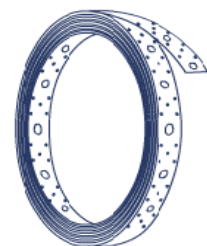



WASHERS FLAT ROUND

ZINC PLATED

* = INDICATES MUDGUARD WASHER



CODE	INSIDE DIAMETER	OUTSIDE DIAMETER	GAUGE	PACK QTY
WF1851622	1/8	5/16	22	200
WF183820	1/8	3/8	20	200
WF181220*	1/8	1/2	20	200
WF185818*	1/8	5/8	18	200
WF5323820	5/32	3/8	20	200
WF53271620	5/32	7/16	20	200
WF31671620	3/16	7/16	20	200
WF3161220	3/16	1/2	20	200
WF3165816	3/16	5/8	16	200
WF3163418*	3/16	3/4	18	200
WF3163416*	3/16	3/4	16	200
WF316116*	3/16	1	16	200
WF31611416*	3/16	1.1/4	16	200
WF141218	1/4	1/2	18	200
WF1491618	1/4	9/16	18	200
WF145818	1/4	5/8	18	200
WF143418*	1/4	3/4	18	200
WF143416*	1/4	3/4	16	200
WF14116*	1/4	1	16	200
WF1411416*	1/4	1.1/4	16	200
WF14216*	1/4	2	16	100
WF5161218	5/16	1/2	18	200
WF5165818	5/16	5/8	18	200
WF5163418	5/16	3/4	18	200
WF5167816	5/16	7/8	16	200
WF5163418	5/16	3/4	18	200
WF5163416*	5/16	3/4	16	200
WF516116*	5/16	1	16	200
WF51611416*	5/16	1.1/4	16	200
WF516216*	5/16	2	16	100
WF385818	3/8	5/8	18	200
WF383416	3/8	3/4	16	200
WF387816	3/8	7/8	16	200
WF38116*	3/8	1	16	200
WF3811416*	3/8	1.1/4	16	200
WF3811216*	3/8	1.1/2	16	200
WF3817814*	3/8	1.7/8	14	100
WF38216*	3/8	2	16	100
WF38212*	3/8	2	12	100
WF7167816	7/16	7/8	16	200
WF716116	7/16	1	16	200
WF12116	1/2	1	16	200
WF1211816	1/2	1.1/8	16	200
WF1211416	1/2	1.1/4	16	200
WF1211214*	1/2	1.1/2	14	200
WF1217814*	1/2	1.7/8	14	200
WF12216*	1/2	2	16	100
WF12212*	1/2	2	12	100
WF91611816	9/16	1.1/8	16	200
WF5811415	5/8	1.1/4	15	200
WF5813815	5/8	1.3/8	15	200
WF58216	5/8	2	16	200
WF3411214	3/4	1.1/2	14	100
WF7815814	7/8	1.5/8	14	100
WF117814	1	1.7/8	14	100



SPRING WASHERS

HEX WASHER HEAD AS3566 CLASS3
ZINC PLATED



IMPERIAL			METRIC		
WS532L	5/32X1/16X3/64		WSM3	M3	
WS316L	3/16X1/16X3/64		WSM4	M4	
WS14L	1/4X3/32X1/16		WSM5	M5	
WS516L	5/16X1/8X5/64		WSM6	M6	
WS38L	3/8X1/8X3/32		WSM8	M8	
WS716L	7/16X5/32X3/32		WSM10	M10	
WS12L	1/2X3/16X1/8		WSM12	M12	
WSL916	9/16X3/16X1/8		WSM14	M14	
WS58L	5/8X7/32X5/32		WSM16	M16	
WS34L	3/4X1/4X3/16		WSM20	M20	
WS78L	7/8X1/4X7/32		WSM24	M24	
WS1L	1X5/16X1/4				

WASHERS FLAT ROUND - METRIC

HEX WASHER HEAD AS3566 CLASS3 ZINC PLATED



CODE	INSIDE DIAMETER	OUTSIDE DIAMETER	GAUGE	PACK QTY
WFM375	3.0MM	7.0MM	0.5MM	200
WFM498	4.0MM	9.0MM	0.8MM	200
WFM5101	5.0MM	10.0MM	1.0MM	200
WFM612512	6.0MM	12.5MM	1.2MM	200
WFM61614	6.0MM	16.0MM	1.4MM	200
WFM81712	8.0MM	17.0MM	1.2MM	200
WFM81916	8.0MM	19.0MM	1.6MM	200
WFM102116	10.0MM	21.0MM	1.6MM	200
WFM102252	10.0MM	22.5MM	2.0MM	200
WFM103025	10.0MM	30.0MM	2.5MM	200
WFM122416	12.0MM	24.0MM	1.6MM	200
WFM12275225	12.0MM	27.5MM	2.25MM	200
WFM16302	16.0MM	30.0MM	2.0MM	200
WFM16504	16.0MM	50.0MM	4.0MM	200
WFM20372	20.0MM	37.0MM	2.0MM	100
WFM24442	24.0MM	44.0MM	2.0MM	100

GALVANISED

WFM61614G	6.0MM	16.0MM	1.4MM	200
WFM81916G	8.0MM	19.0MM	1.6MM	200
WFM10232G	10.0MM	22.5MM	2.0MM	200
WFM12282G	12.0MM	27.5MM	2.0MM	100
WFM163425G	16.0MM	34.0MM	2.5MM	100
WFM16503G	16.0MM	50.0MM	3.0MM	100
WFM20383G	20.0MM	38.0MM	3.0MM	100
WFM24524G	24.0MM	52.0MM	4.0MM	100
WFM24716G	24.0MM	71.0MM	6.0MM	100
WFM30584G	30.0MM	58.0MM	4.0MM	100

HIGH TENSILE WASHERS



CODE	SIZE	PRODUCT CODE	SIZE
WFHT716	7/16X22.5X2.0	WFMHTM8	M8X18.0X2.0
WFHT38	3/8X27.0X3.0	WFMHTM10	M10X21.0X2.0
WFHT12	1/2X27.0X3.0	WFMHTM12	M12X27.0X4.0
WFHT58	5/8X33.0X3.0	WFMHTM14	M14X30.0X4.0
		WFMHTM16	M16X34.0X4.0



INTERNAL & EXTERNAL LOCK WASHERS

ZINC PLATED



CODE	SIZE	PRODUCT CODE	SIZE
WLI18	1/8	WLI3	M3
WLI532	5/32	WLI4	M4
WLI316	3/16	WLI5	M5
WLI14	1/4	WLI6	M6
WLI516	5/16	WLI8	M8
WLI38	3/8	WLI10	M10
WLI12	1/2	WLI12	M12

Note : Code for External Lock Washer Example WLE18 = 1/8"

RED FIBRE WASHERS

IMPERIAL



CODE	INSIDE DIAMETER	OUTSIDE DIAMETER	GAUGE	PACK QTY
WFR18516116	1/8	5/16	1/16	1000
WFR53238116	5/32	3/8	1/16	1000
WFR316716116	3/16	7/16	1/16	1000
WFR1412116	1/4	1/2	1/16	1000
WFR51658116	5/16	5/8	1/16	1000
WFR3834116	3/8	3/4	1/16	1000
WFR121116	1/2	1	1/16	1000

SPECIAL RED FIBRE WASHERS FOR WIRE IN ROOFING APPLICATIONS

WFR180120132	.180 (4.57mm)	1.20 (30.5mm)	1/32	1000
--------------	---------------	---------------	------	------

NYLON WASHERS

IMPERIAL AND METRIC



CODE	INSIDE DIAMETER	OUTSIDE DIAMETER	GAUGE	PACK QTY
WN31612132	3/16	1/2	1/32	1000
WN1412132	1/4	1/2	1/32	1000
WN388	3.0MM	8.0MM	0.8MM	1000
WN478	4.0MM	7.0MM	0.8MM	1000
WN51128	5.0MM	11.2MM	0.8MM	1000
WN6141	6.0MM	14.0MM	1.0MM	1000
WN8161	8.0MM	16.0MM	1.0MM	1000
WN102115	10.0MM	21.0MM	1.5MM	1000
WN122515	12.0MM	25.0MM	1.5MM	1000

BRASS SCREW CUP WASHER

NICKEL PLATED



CODE	SIZE	PACK QTY
WC6	No.6	1000
WC8	No.8	1000
WC10	No.10	1000

SCREW DRIVER BITS - MAGNETISED

PHILLIPS INSERT BITS

1/4" HEX DRIVE



Code	Point Size	Length MM	Pack Qty			
PH125S	No.1	25	10	Magnetised		
PH225S	No.2	25	10	Magnetised		
PH325S	No.3	25	10	Magnetised		
PH332516I	No.3	32	10	Magnetised	5/16 Hex Shank	
PH425S	No.4	25	10	Magnetised		

PHILLIPS DOUBLE ENDED POWER BITS

1/4" HEX DRIVE



Code	Point Size	Length MM	Pack Qty			
PH245D	No.2	45	10	Magnetised		
PH265D	No.2	65	10	Magnetised		
PH275D	No.2	75	10	Magnetised		
PH2150D	No.2	150	10	Magnetised		

PHILLIPS POWER BITS

1/4" HEX DRIVE



Code	Point Size	Length MM	Pack Qty			
PH150S	No.1	50	10	Magnetised		
PH1100S	No.1	100	10	Magnetised		
PH250S	No.2	50	10	Magnetised		
PH275S	No.2	75	10	Magnetised		
PH2100S	No.2	100	10	Magnetised		
PH2150S	No.2	150	10	Magnetised		
PH2200S	No.2	200	10	Magnetised		
PH2250S	No.2	250	10	Magnetised		
PH350S	No.3	50	10	Magnetised		
PH375S	No.3	75	10	Magnetised		
PH3100S	No.3	100	10	Magnetised		
PH3150S	No.3	150	10	Magnetised		

PHILLIPS REDUCED HEAD POWER BITS

1/4" HEX DRIVE



Code	Point Size	Length MM	Pack Qty			
PHR250S	No.2	50	10	Magnetised		
PHR289S	No.2	89	10	Magnetised		

PHILLIPS RIBBED POWER BITS

1/4" HEX DRIVE



Code	Point Size	Length MM	Pack Qty			
PHR275SR	No.2	75	10	Magnetised		
PHR2100SR	No.2	100	10	Magnetised		



IMPACT DRIVER BITS - THUNDERZONE

PHILLIPS POWER BITS

1/4" HEX DRIVE



Code	Point Size	Length MM	Pack Qty		Alpha Code	
PH225SI	No.2	25	10	Magnetised	PH25SSH	
PH250SI	No.2	50	10	Magnetised	PH250SSH	
PH275SI	No.2	75	10	Magnetised	PH275SSH	
PH2100SI	No.2	100	10	Magnetised	PH2100SSH	
PH2150SI	No.2	150	10	Magnetised	PH2150SSH	



MAXDRIVE TORSION BITS

PHILLIPS POWER BITS

1/4" HEX DRIVE



MAXDRIVE TORSION BITS absorb stress in their specially engineered "Dual Torsion Zone" and combined with a specially formulated coating relieve pressure on the tip of the driver bit, giving greater durability and less breakage. MAXDRIVE TORSION BITS are ideally suited to impact driving and will give exceptional performance with standard usage.

Code	Point Size	Length MM	Pack Qty		Alpha Code	
PH250ST	No.2	50	10	Magnetised	PH250ST	
PH275ST	No.2	75	5	Magnetised	PH275ST	
PH2100ST	No.2	100	5	Magnetised	PH2100ST	
PH2150ST	No.2	150	1	Magnetised	PH2150ST	

SLOTTED POWER BITS

1/4" HEX DRIVE



Code	Screw Size	Length MM	Pack Qty			
SL350S	3-4	50	10	Magnetised		
SL550S	5-6	50	10	Magnetised		
SL650S	6-10	50	10	Magnetised		

TRI-LOBULAR INSERT BITS
1/4" HEX DRIVE



Code	Length MM	Pack Qty			
TRI-LOB	25	10			

TORX INSERT BITS
1/4" HEX DRIVE



Code	Point Size	Length MM	Pack Qty			
TORX1025S	TX10	25	10	Magnetised		
TORX1525S	TX15	25	10	Magnetised		
TORX2025S	TX20	25	10	Magnetised		
TORX2525S	TX25	25	10	Magnetised		
TORX3025S	TX30	25	10	Magnetised		
TORX4025S	TX40	25	10	Magnetised		
480TX55	T-55	25	EA	5/16" HEX SHK		

TORX POWER BITS
1/4" HEX DRIVE



Code	Point Size	Length MM	Pack Qty			
TORX1075S	TX10	75	10	Magnetised		
TORX2050S	TX20	50	10	Magnetised		
TORX2075S	TX20	75	10	Magnetised		
TORX2550S	TX25	50	10	Magnetised		

TORX SECURITY INSERT BITS - POST HOLE
1/4" HEX DRIVE



Code	Point Size	Length MM	Pack Qty			
TORXSE825S	TX8	25	10	Magnetised		
TORXSE1025S	TX10	25	10	Magnetised		
TORXSE1525S	TX15	25	10	Magnetised		
TORXSE2025S	TX20	25	10	Magnetised		
TORXSE2525S	TX25	25	10	Magnetised		
TORXSE3025S	TX30	25	10	Magnetised		
TORXSE4025S	TX40	25	10	Magnetised		

HEX DRIVE INSERT BITS
1/4" HEX DRIVE



Code	Point Size	Length MM	Pack Qty			
HEX430S	4mm	30	10	Magnetised		
HEX530S	5mm	30	10	Magnetised		
HEX632S	6mm	32	10	Magnetised		

HEX DRIVE POWER BITS
1/4" HEX DRIVE



Code	Point Size	Length MM	Pack Qty			
HEX350S	3mm	50	10	Magnetised		
HEX450S	4mm	50	10	Magnetised		
HEX550S	5mm	30	10	Magnetised		

SCREW DRIVER BITS - MAGNETISED

SQUARE RECESS POWER BITS

1/4" HEX DRIVE



Code	Point Size	Length MM	Pack Qty			
SQ150S	1	50	10			
SQ250S	2	50	10			
SQ275S	2	75	10			
Thundezone Impact Bit						
SQ350S	3	50	10			



MAGNETIC BIT HOLDERS - C-RING (One piece)

1/4" HEX DRIVE



Code	Insert Bit Size	Length MM	Pack Qty	OLD CODE		
MBHCS54	1/4"	54	10	40831		
MBHCS75	1/4"	75	10	27690		
2 Piece						
MBHC150	1/4"	150	10			
MBHC300	1/4"	300	10			

QUICK RELEASE PRO BIT HOLDER - ALPHA

1/4" HEX DRIVE



MBHQR65	1/4"	65MM	EA			
MBHQR150	1/4"	150MM	EA			

MAGNETIC SOCKETS



HEX NUTSETTERS

1/4" HEX DRIVE



Code	Hex Size	Length MM	Pack Qty	OLD CODE		
NS1442	1/4"	42	EA	31450		
NS51642	5/16"	42	EA	31452		
NS3842	3/8"	42	EA	36165		
NS1465	1/4"	65	EA	37582		
NS51665	5/16"	65	EA	37583		
NS3865	3/8"	65	EA	37584		
EXTRA LONG SOCKETS						
NS516150	5/16"	150	EA			
NS516200	5/16"	200	EA			
NS516300	5/16"	300	EA			
NS38150	3/8"	150	EA			



SCREW DRIVER BITS AND SETS



POZI INSERT BITS - 1/4" HEX DRIVE

Code	Point Size	Length MM	Pack Qty			
PZ125S	1PZD	25	10	Magnetised		
PZ225S	2PZD	25	10	Magnetised		
PZ325S	3PZD	25	10	Magnetised		
POZI Power Bits						
PZ150S	1PZD	50	10	Magnetised		
PZ250S	2PZD	50	10	Magnetised		



HEX TO SQUARE ADAPTOR



ADP14-65		65	EA	1/4" Hex to 1/4" Square	
ADP14-150		150	EA	1/4" Hex to 1/4" Square	
ADP38-50		50	EA	1/4" Hex to 3/8" Square	
ADP38-75		75	EA	1/4" Hex to 3/8" Square	
ADP12-70		70	EA	1/4" Hex to 1/2" Square	

33 PCE INSERT SET 1/4" HEX DRIVE



CODE: RBT33

This set contains:

- 1xPH1, 6xPH2, 1xPH3 Phillips
- 1xPZ1, 1xPZ2, 1xPZ3 Pozidrive
- 1x1.5, 1x2, 1x2.5, 1x3, Metric Hex 2x4, 2x5, 1x6
- 1x4.5, 1x6 Slotted
- 1xT10, 1xT15, 1xT20, Torx 1xT25, 1xT27, 1xT30, 1xT40
- 1xSQ1, 1xSQ2, 1xSQ3 Square Recess
- 1 X Quick Release Bit Holder

100 PCE SECURITY SET 1/4" HEX DRIVE



CODE: EW-100

This set contains:

- 6 x Fractional Hex Tamper Proof
- 8 x Phillips
- 8 x Pozidrive
- 10 x Fractional Hex
- 9 x Metric Hex
- 3 x Torq Set
- 4 x Spanner
- 9 x Slotted
- 6 x Metric Hex Tamper Proof
- 9 x Tamper Proof Torx
- 9 x Torx
- 4 x Triwing
- 3 x Spline
- 4 x Square Recess
- 3 x Clutch

1 x 1/4" Sq x 1/4" Hex 25mm Ext, 1 x 1/4" Sq x 1/4" Hex 50mm Ext
1 x Magnetic Bit Holder, 1 x Socket Bit Holder, 1 x Wing Nut Driver.



SHOCKPROOF MAGNETIC SCREWDRIVER HANDLE





Comes with 4 bits.



CODE: 68888

PAGE 95



AIR FITTINGS - NITTO STYLE

DESCRIPTION	CODE	SIZE	NITTO No	PKT QTY	MATERIAL
BSPT THREADED MALE PLUGS					
	N20PM	1/4	20PM	1	
BSPP THREADED FEMALE PLUGS					
	20PF	1/4	20PF	1	
BARBED MALE PLUGS					
	30PH	3/8 Hose	30PH	1	
BARBED MALE COUPLER					
	30SH	3/8 Hose	30SH	1	

BLOW GUN AIRBOY PISTOL GRIP					
	00441830			1	PLASTIC
AIRSAW BLADE18	Reciprocating Saw Blade 18 TPI			EA	
AIRSAW BLADE24	Reciprocating Saw Blade 24 TPI			EA	

Redback Teflon Tape

Redback Teflon Tape is the No.1 on the market, designed to replace irritating cheap and inferior tape. It doesn't fray when you tear it or come off the spool when under tension. Red Back Teflon is twice as thick as other brands which reduces the amount of tape required.



Code	Description	List Price
RED409	Roll	2.00



Quick change spring loaded sleeve.
To suit Quickbits, Spade Bits & Screwdriver Bits

Code	Hex Size	Length MM	Pack Qty			
107QBE300	1/4"	300	EA			
107QBE450	1/4"	450	EA			
107QBE600	1/4"	600	EA			









JIGSAW BLADES

T SHANK

DESCRIPTION	CODE	USEABLE LENGTH MM	TOOTH SPACING MM	BLADES PER CARD	BOSCH CODE
BASIC FOR WOOD					
HCS hardwood, soft wood, plastics 4-50mm, for fast rough cuts.	623632	74	3	5	T111C
CLEAN FOR WOOD					
HCS Soft wood, chipboard, wood core plywood, fibre boards, plastics, clean cuts with plunge tip.	623969	74	1.5	5	T101B
HCS Hardwood, softwood, chipboard, wood core plywood, fibre boards, laminated boards, clean cuts, reverse tooth	623650	74	2.5 Reverse	5	T101BR
EXTRA CLEAN FOR WOOD					
HCS perfect, splinter-free cutting results on both sides, for fast cuts, Soft Wood. Caution:deactivate the pendulum action!	623998	93	2.2	5	T308B
BASIC FOR METAL					
HSS Thin sheet metal. 1-3mm, non-ferrous metals.	623637	51	1.2	5	T118A
HSS Thin sheet metal 1-3mm, non-ferrous metals, sandwich materials.	623629	106	1.2	5	T318A
HSS Steel sheets 0.5-1.5mm, non-ferrous metals.	623636	66	0.7	5	T118G
HSS Steel sheets, 2.5-6mm, non-ferrous metals.	623638	51	2	5	T118B
HSS Medium thick metal plate (2.5-6mm), non-ferrous metals	623697	106	2	5	T318B
PROGRESSOR FOR METAL					
BiM Thin to thick sheet metal (1.5-10mm), non-ferrous metals to 30mm	623676	74	1.4 - 2.6	5	T123X
SPECIAL FOR ALUMINIUM					
HSS Aluminium 3-15mm, non-ferrous metals 4-20mm, plastics, for quick cuts.	623639	74	3	5	T127D
MAKITA SHANK <small>clean wood</small>					
HCS Soft wood, chipboards, wood core plywood, fibre boards,plastics/epoxy.	H4258703	75	3	5	MA101BC

SABRE SAW BLADES (RECIPROCATING BLADES)

DESCRIPTION	CODE	OVERALL LENGTH MM	TOOTH SPACING MM	BLADES PER CARD	APPLICATION THICKNESS MM
FLEXIBLE FOR METAL					
BiM thin sheet metal effortless, fine cut.	628268	100	1.41	5	0.7 - 3
					
BiM metal sheets (.7-3mm), pipes/profiles .5-100mm.	631080	150	1.4	2	.5 - 100
					
BiM metal sheets 3-8mm), pipes/profiles 10-175mm flush cuts.	631494	225	1.8	5	10 - 175
					
BiM metal sheets 1.5-4mm, solid pipes/profiles 5-175mm, flush cut.	631493	225	1.4	5	5 - 175
					
WORKING IN WOOD WITH METAL					
BiM wood with nails/metal 5-150mm, sheetmetal, pipes, profiles 3-18mm	631915	200	Progressive	5	5 - 150
					
BiM wood with nails, plastics, chipboards 3 - 175mm.	631097	225	1.8-2.6	2	5 - 175
					
WORKING IN WOOD					
HCS wood (even damp), firewood, for fast rough cut 15-190mm	631488	240	5	5	15 - 190
					

HAND HACKSAW BLADES & FRAMES

BI METAL FLEXIBLE HSS	HBB1218	12"	300	18	100		
BI METAL HSS SUTTON	HBBH1224	12"	300	24	100		
BI METAL FLEXIBLE HSS	HBB1232	12"	300	32	100		



CODE: HF-506



CODE: HF-40T



SILICONE SEALANTS



CODE: SILICONE300T = Trans
 SILICONE300G = Grey
 SILICONE300B = Black
 SILICONE300W = White
 SILICONE300MB = Matt Black
 300G TUBE

FulaSeal PRO™ 300 is a premium grade, neutral cure, 100% silicone sealant specially formulated for use in glazing, construction and industrial fabrication where a premium quality, non-corrosive sealant is required.

FulaSeal PRO™ 300 combines a high level of resistance to temperature, weathering, and UV exposure with excellent adhesion, flexibility and durability. FulaSeal PRO™ 300 can also be used as an adhesive where a highly flexible, waterproof, high temperature resistant bond line is required. Is AS4020-2005 Potable Water Approved.

Substrates: Ceramic, Glass, Concrete, Plasterboard, Timber, Metal, Steel Inc. Stainless, Zinc/Galvanised Steel Aluminium and Some plastics (pre-test).



CODE: SILICONE780A = Aluminium
 300G TUBE

FulaSeal™ 780 Plumbers Silicone Sealant is a non-corrosive neutral cure sealant that can be used on a wide range of substrates. It is ideal for roofing applications, exterior cladding, guttering, flashing, downpipes, general plumbing and is compatible with drinking water storage systems.

Substrates: Steel, Aluminium, Zinc/galvanised steel, Masonry, Ceramic, Lead, Fibreglass, Plasterboard, Terracotta, Many plastics (pre-test) and Glass.



CODE: SILICONE770T = Translucent
 SILICONE770W = White
 300G TUBE

FulaSeal™ 770 Sanitary Silicone Sealant is a premium quality, 100% silicone sealant specifically designed for use in wet areas where a neutral cure sealant is required that contains a mould and mildew inhibitor.

FulaSeal™ 770 Sanitary Silicone a professional quality wet area sealant that provides excellent adhesion and is suitable for contact with aluminium shower screens and other substrates susceptible to corrosion.

Substrates: Steel inc stainless, Aluminium, Galvanised steel, Masonry, Ceramic, Zinalume, Laminated Plastic, Glass, Fibreglass and Many plastics (pre-test).



CODE: SILICONE740W = White
 300G TUBE

FulaSeal™ 740 Bathroom & Kitchen Silicone Sealant is specifically designed for use in wet area joint sealing applications involving non-porous surfaces commonly found in bathrooms, kitchens and laundries, such as porcelain, glass and ceramic tiles. FulaSeal™ 740 is acetic cure.

Substrates: Vitreous china, Glass, Timber, Ceramic tiles, Fibreglass, Baked enamel surfaces, Plasterboard, Stainless and many plastics (pre-test).

SEALANTS & ADHESIVES



CODE: SILICONEOW = Off White

300G TUBE

All Purpose Silicone is a very versatile flexible sealant and adhesive that can be used for a wide range of applications. It offers excellent adhesive properties, flexibility, waterproofing and temperature resistance that makes it ideal for sealing a variety of surfaces and materials from roofs and gutters to bathroom tiles.

All Purpose Silicone includes a mould inhibitor making it ideal for wet areas. Neutral cure sealant.

Substrates: Steel, Aluminium, Galvanised iron, Timber, Brick, Concrete, Masonry, Glass, Fibreglass and Ceramic tile.



CODE: TOOLBOXBLACK= Black

TOOLBOXWHITE= White

400G TUBE



CODE: TOOLBOXW600 = White

600ML SAUSAGE

Tool Box™ Original is a high performance multi-purpose adhesive and sealant in one based on MS polymer technology. Tool Box™ Original cures to form a high strength, permanently flexible waterproof bond adhering to a wide variety of materials. It performs the function of both a high strength adhesive as well as a highly durable joint sealant. Tool Box™ Original provides a non-hazardous alternative to traditional polyurethane elastomeric adhesive/sealants and is a true 'tool box' in a cartridge.

Substrates: Concrete, Fibre cement sheeting, Masonry/brick, Cement tiles, Glass/standard mirrors, Porcelain, Steel inc stainless, Zinc/galvanised steel, Aluminium, Polystyrene, Plasterboard, Timber, Fibreglass, Acrylic, ABS.



CODE: TOOLBOXINVISIBLE = Clear

290ML TUBE

Tool Box™ Invisible is a clear multi-purpose hybrid polymer adhesive and sealant with outstanding clarity.

Tool Box™ Invisible is ideal for creating invisible seals™ and for bonding a wide variety of materials to create a durable, high strength, waterproof bond-line.

Substrates: Concrete, Fibre cement sheeting, Steel inc galvanised, Aluminium, Glass, Timber, Plasterboard, Polystyrene, Most plastics and rubbers (pre test).



CODE: TOOLBOXHT = White

290ML TUBE

Tool Box™ High Tack is a high modulus, elastomeric hybrid polymer adhesive/sealant with superior instant grab strength. Its high aggressive tack makes it ideal for bonding heavy objects and eliminates the need for mechanical fixing, bracing or propping during the curing process.

Substrates: Concrete, Fibre cement sheeting, Masonry/brick, Cement tiles, Glass/standard mirrors, Porcelain, Steel inc stainless, Zinc/galvanised steel, Aluminium, Polystyrene, Plasterboard, Timber, Fibreglass, Acrylic, ABS.



CONSTRUCTION ADHESIVES & SEALANTS



CODE: NONAILSHBF

300G TUBE

Fuller Trade Construction Adhesive is a multi-purpose adhesive ideal for bonding most common building materials. Fuller Trade Construction Adhesive is compatible with most common construction substrates

Substrates: Concrete, Fibre cement sheeting, Masonry, Metal, Timber, Particleboard, Plywood, Plasterboard, Ceramic Tiles, Glass, Fibreglass.



CODE: COOLROOMHB840NS

460G TUBE

FulaSeal PRO™ 840NS is a non-skinning and non-corrosive polybutene based sealant, designed specifically for small joints in cool room installation. FulaSeal PRO™ 840NS is also suitable for concealed lap joints between plastics, metals and a wide range of common substrates.

Substrates: Metal inc. coated metals, Steel inc. stainless, Galvanised steel, Aluminium, Sandwich Panels, Alucobond, Zinalume, Plastics (pre-test), Polystyrene, Fibreglass, Timber.



CODE: GAPSEAL = White

450G TUBE

Fuller Trade Gap Filler is a general purpose water based acrylic gap filler, suitable for use on interior and exterior areas prior to painting. It offers excellent adhesion properties suitable for sealing gaps and low movement joints. Fuller Trade Gap Filler can be used on: Skirting boards, Architraves, Plasterboard, Window and door frames.

Substrates: Brick, Concrete, Masonry, Fibre cement sheeting, Plasterboard, Aluminium, Ceramic, Timber, Particleboard Polystyrene.



CODE: SILICONEFIREG = Grey

450G TUBE



CODE: SILICONEFIREG600 = Grey

600ML SAUSAGE

Firesound™ Fire Rated Acoustic Sealant is a premium quality, flexible construction sealant formulated to perform as a barrier to the passage of both fire and sound through construction joints and service penetrations in concrete, aerated concrete, block work, brickwork and fire-rated plasterboard.

Substrates: Concrete, Aerated concrete, Mortar, Brick, Masonry, Fire rated plasterboard, Aluminium, Steel inc. stainless, Zinc/galvanised steel, Cable coverings (PVC).



PERFORMANCE SEALANTS



CODE: FULAFLEX550LMB = Black
FULAFLEX550LMG = Grey
FULAFLEX550LMW = White
310ML TUBE



CODE: FULAFLEX550LMB600 = Black
FULAFLEX550LMG600 = Grey
FULAFLEX550LMW600 = White
600ML SAUSAGE

FulaFlex™ 550LM is a one component moisture-curing low modulus Class A polyurethane sealant with excellent joint movement capabilities. It cures to form a flexible, durable and weather proof sealant and exhibits excellent adhesion to a wide range of common construction substrates. FulaFlex™ 550LM is paintable and satisfies the requirements for the Green Building Council of Australia (GBCA).

Substrates: Concrete, Fibre cement sheeting, Ceramic, Masonry, Brick, Plasterboard, Metal, Timber Steel inc. stainless, Zinc/galvanised steel, Aluminium (uncoated)*,

* pre-test powder coated aluminium surfaces due to the wide range of available coatings



CODE: FULAFLEX650FCW = White
420G TUBE



CODE: FULAFLEX650FCB600 = Black
FULAFLEX650FCG600 = Grey
FULAFLEX650FCW600 = White
600ML SAUSAGE

Fulaflex™ 650FC is a high performance, solvent free, moisture curing hybrid polymer construction and industrial adhesive/sealant that provides a non-hazardous alternative to traditional polyurethane adhesive/sealants. It cures to form a seal that is tough, elastic and weatherproof with good chemical resistance. FulaFlex™ 650FC is a high modulus product ideal in bonding applications where differential expansion and contraction are anticipated. FulaFlex™ 650FC is paintable

Substrates: Concrete, Fibre cement sheeting, Masonry/brick, Ceramic, Steel/stainless, Zinc/galvanised steel Aluminium, Polystyrene, Plasterboard, Timber, Particleboard, Polystyrene, Many plastics (pre test).



CODE: FULAFLEX625G = Grey
440G TUBE

FulaFlex™ 625 is a construction grade joint sealant suitable for expansion joints in large structures, joints in precast concrete elements and general sealing applications. With superior permanent flexibility, FulaFlex™ 625 is a low VOC premium sealant that is tough, weatherproof, paintable and easy to apply in both interior and exterior applications. Ideal for sealing expansion & control joints in tiling, roof & wall penetrations up to 35mm. Sealing door and window frame perimeters, cladding and brickwork joints.

Substrates: Concrete, Fibre cement sheeting, Masonry/brick, Ceramic, Steel/stainless, Zinc/galvanised steel Aluminium, Polystyrene, Plasterboard, Timber, Particleboard, Polystyrene, Many plastics (pre test).

Foam Fillers



CODE: 15019420 - FulaFoam 750ml with straw nozzle

CODE: 15019467 - FulaFoam Pro 750ml gun applied foam

FulaFoam™ Expanding Foam is a triple expanding, general purpose polyurethane foam designed to fill large gaps, holes and cavities. FulaFoam™ Expanding Foam can be used internally and externally, bonds to most common construction materials to provide an airtight, moisture resistant seal with excellent thermal insulation properties. Ideal for sealing holes, around plumbing and electrical penetrations through walls and floors, filling wide gaps and cracks around window frames. Also for sealing against draughts, moisture and noise.

Substrates: Concrete, Brick, Fibre cement sheeting, Timber, Plywood, Particleboard, Plasterboard, Fibreglass, Zinc/galvanised steel, Steel inc. stainless, Aluminium



CODE: FOAMFULAFIRE - FulaFoam FR 750ml with straw nozzle

FulaFoam™ Fire Resistant Expanding Foam is a single component, fire resistant polyurethane expanding foam filler. FulaFoam™ Fire Resistant can provide up to 3 hours fire resistance (appraised to AS1530.4) and provides high acoustic insulation. FulaFoam™ Fire Resistant will not shrink during curing and will provide an air- and smoke-tight seal. The cured foam can be cut, sanded, plastered or painted.

Substrates: Concrete, Mortar, Fibre cement sheeting, Timber, MDF, Particleboard, Steel inc. stainless, Zinc/galvanised steel, Aluminium, Plasterboard, Fibreglass, Ceramics

CODE: 85001662 - Economy Foam Gun

CODE: FOAMCLEANERFULA - 500ml Can



The H.B Fuller foam dispensing applicator gun is designed to fit all Pro Gun series cans including Max Bond Pro Gun Construction Adhesive and FulaFoam Pro Gun Expanding PU Foams. Engineered for long term use, with proper care and cleaning, the foam applicator gun is sure to last.



FulaFoam™ Cleaner is a solvent based cleaner for cleaning uncured or fresh polyurethane from applicator guns, tools and other surfaces. FulaFoam™ Cleaner can be used to clean applicator guns used for FulaFoam Pro and Max Bond Pro gun-applied foams and adhesives.

CAULKING GUNS



Easy Squeeze Caulking Gun

For most adhesive and sealant products the Easy Squeeze Caulking Gun is perfect. The skeleton body makes changing cartridges quick and easy and the 7:1 compression ratio makes dispensing adhesives and silicones a breeze.

CODE: SILICONEGUNL



Tough Red Cartridge Gun

Designed for long term use especially when working with adhesives and sealants that are high grab or highly viscous. The 18:1 compression ratio makes dispensing easier and reducing hand fatigue.

CODE: SILICONEGUNHD



Sausage Barrel Caulking Gun

Engineered for trade using quality materials and components with ergonomics, performance and reliability in mind. The cast frame/handle assembly will not deform with prolonged use and the trigger offers a smooth action for clean bead application.

CODE: SILICONEGUN600

SILICONE SEALANTS



CODE: ADHESIVEMAXBOND - 500ml Can

Max Bond Spray Grip™ is a general purpose contact adhesive that bonds to a wide variety of substrates. Spray Grip™ offers high initial bond strength for instant results and is suitable for fast bonding applications without the need for clamping. Ideal for adhering breathable building insulation wrap. Bonding metal edge bead to plasterboard. Bonding fibre reinforced laminate to plasterboard, bonding and laminating involving MDF, etc.

Substrates: Metals, MDF & Plywood, Plasterboard, Acrylic, Synthetic leather, Fibre reinforced laminates, Polyurethane foam, Paper/Cardboard, Many plastics (Pre-test), Fabric (Pre-test), Rubber (Pre-test).



CODE: DUCTSEAL3219 = Grey

450G TUBE

Foster 32-19 Duct-Fas Duct Sealant is a fire resistive, water based, indoor/outdoor, U.V. resistant, non-fibrated sealant for use on high velocity ducts to form a flexible yet durable seal against air leakage. Foster Duct-Fas Duct Sealant has been specially formulated for ease of application, clean "break-off", and non-slumping at elevated temperatures. Ideal for sealing ASJ, FRK, and FSK jackets Sealing board facings at joints, laps, over staple and weld pin punctures. Sealing flexible air ducts to rigid connectors Ideal for use as a joint sealant with polystyrene insulation.

Substrates: Zinc/galvanised steel, Aluminium, Polystyrene.

CODE: 10016685 = 1kg Can

10016690 = 2kg Can



FulaFill™ Swift Multi Surface Builders Bog is a versatile two-part polyester filler. It mixes, applies, and sands effortlessly, making it ideal for filling gaps, cracks, holes, and other imperfections in most common building materials where no movement is expected. Once cured, FulaFill™ Swift Builders Bog can be painted, sanded, chiselled, planed, filed, nailed, screwed, or routed.

Substrates: Timber, MDF, Fibreglass, Particleboard, Most metals, Steel, Aluminium, Fibre cement sheeting, Masonry, Concrete, Plasterboard, Ceramics.

SEALANTS - POLYURETHANE ADHESIVES



Sikaflex® - PRO High Strength Polyurethane Sealant

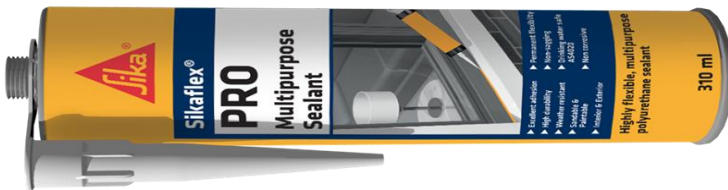

CODE

SIKAFLEXPROB300 = Black
 SIKAFLEXPROG300 = Grey
 SIKAFLEXPROW300 = White
 310ml Tube

Sikaflex® - PRO is a multipurpose permanently elastic sealant that provides excellent adhesion while allowing high flexibility for accommodating joint movement. For bonding applications use Sikaflex 11FC.

- Expansion joints in buildings
- Construction joints
- Joints in precast concrete elements
- External walling and cladding joints
- Infill panel joints
- Curtain walling
- Sanitary installations
- Sealing around window and door frames
- Flexible draught proofing
- Sealing penetrations in walls or floors for ducts, piping etc

Sikaflex® - PRO SAUSAGES 600ml



CODE

SIKAFLEXPROB600 = Black
 SIKAFLEXPROG600 = Grey
 SIKAFLEXPROW600 = White
 600ml Sausage

Sikaflex® - 11FC 1-Part Elastic Joint Sealant & Multipurpose Adhesive



CODE

SIKAFLEX11FCB300 = Black
 SIKAFLEX11FCG300 = Grey
 SIKAFLEX11FCW300 = White
 310ml Tube

Sikaflex® - 11FC is a one part, moisture curing, elastic joint sealant and multipurpose adhesive based on polyurethane for indoor and outdoor applications.

Sikaflex® - 221 One Component Adhesive Sealant



CODE

SIKAFLEX221B300 = Black
 310ml Tube

Sikaflex® - 221 is a high-quality multipurpose non-sag 1-C polyurethane sealant that cures on exposure to atmospheric humidity to form a durable elastomer.

Sikaflex® - 252 Assembly Adhesive



CODE

SIKAFLEX252W300 = White
 310ml Tube

Sikaflex® - 252 is suitable for structural joints that will be subjected to dynamic stresses. Suitable substrate materials are timber, metals, particularly aluminium, sheet steel, ceramic materials and plastics.

SEALANTS - POLYURETHANE ADHESIVES

Sikaflex® - Aktivator-100

Sikaflex® - Aktivator-100 is an activating agent to improve adhesion. It is specifically formulated for the treatment of bond faces prior to application of various Sika polyurethane adhesives.

CODE

SIKA-AKTIV100

Bottle 1ltr



PIPE FLASHINGS - AQUADAPTS



Benefits

Suitable for both standard and retrofit application.

Wraps around existing pipes.

Suitable for repairs.

Full range of sizes.

Polymer is Ozone and UV resistant.

20 year warranty.

BAL certified.



AQUADAPT No.	Black EPDM Code	Red Silicone Code	METRIC Pipe Sizes 25° Roof Pitch	METRIC Pipe Sizes 45° Roof Pitch	Base Size mm	Max Retro Clips Required	
No. 1	AQUA1B		8 - 50mm	8 - 40mm	115x115	4	
No. 1		n/a					
No. 2	AQUA2B		10 - 90mm	10 - 70mm	155x155	5	
No. 2		AQUA2R					
No. 3	AQUA3B		40 - 100mm	40 - 90mm	203x203	5	
No. 3		AQUA3R					
No. 4	AQUA4B		75 - 150mm	75 - 135mm	255x255	6	
No. 4		AQUA4R					
No. 5	AQUA5B		125 - 200mm	125 - 180mm	305x305	6	
No. 5		AQUA5R					
No. 6	AQUA6B		145 - 250mm	145 - 230mm	355x355	7	
No. 6		AQUA6R					
No. 7	AQUA7B		195 - 300mm	195 - 250mm	432x432	7	
No. 7		AQUA7R					
No. 8	AQUA8B		230 - 380mm	230 - 355mm	540x600	9	
No. 8		AQUA8R					
No. 9	AQUA9B		315 - 500mm	315 - 450mm	650x720	11	
No. 9		AQUA9R					
No. 10	AQUA10B		400 - 750mm	400 - 630mm	965x995	15	
No. 10		AQUA10R					

EPDM will withstand constant temperatures of -40°C to 115°C
 Silicone will withstand constant temperatures of -50°C to 240°C

Part No	Description	Material	Pack	
AQUADAPT CLIPS				
AQUACLIPA	Clip for retro-fitting Aquadapts	Aluminium	50	

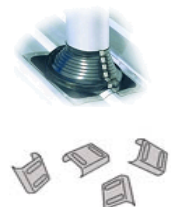

EXPANSION STRIP JOINT 145MM

Part No	Description	Expansion Range	Material	Pack
ESJ145-5	Expansion Strip Joint Replaces the need to box the end of two adjoining gutters and also the need to form a bridge to span the boxed ends. The biggest benefit, other than ease of installation is that in case of a blocked downpipe any water can flow across to the adjoining gutter eliminating flooding.	145 to 175mm	EPDM	1 X 5MTR

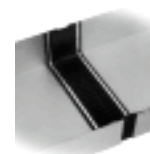

GRAB STICK

GRABSTICK The ultimate magnetic holding tool can hold all types of metal roofing or fencing, it will temporarily retain insulation foils and sarking on walls and roofs, it can hold a measuring tape or stringline in place, and can aid tradespeople as they drill cut or machine, its like having an extra pair of hands.



ROOFING SCREW WASHERS

DESCRIPTION	CODE	SIZE	COLOUR	MATERIAL	PACK QTY	PRICE PKT
Dome Washers						
	WDOME26	26MM	GREY	EPDM	1000	
Weatherlok Washers						
	WEATHERLOK	32MM	GREY		1000	
Embossed Washers						
	WEA121425	25MM	12-14G	ALUM	1000	



FLASHTAC - Weather Proofing Tape

Bear Flashtac Tape is a self-adhesive laminate tape designed for temporary repairs. Its reinforced aluminium cover film and bitumen rubber compound is highly adhesive to many construction materials. Surfaces, edges and rabbets are completely covered and sealed. The tape is impermeable to water vapour and oxygen. The silver finish allows visually inconspicuous applications. Offers long lasting and weather resistant results.

- A versatile bitumen tape that forms an extremely durable weather seal. Paintable aluminium backing.
- Ideal for temporary sealing, flashing, repairing, water and weather proofing most surfaces.
- The strong self adhesive bitumen base membrane is designed for permanent repairs.

Part No	Description	Box Qty	Price Roll
FLASHTAC96X10M	FLASHTAC TAPE 414-S 96MM X 10M	3	



Tekkit Touch-Up Paint Marker



Tekkit Touch-Up Paint Marker

A unique touch-up paint pen





Designed to touch-up scratches and marks on the Colorbond® range of steel

Ideal for use on garages, fencing, guttering and roofs

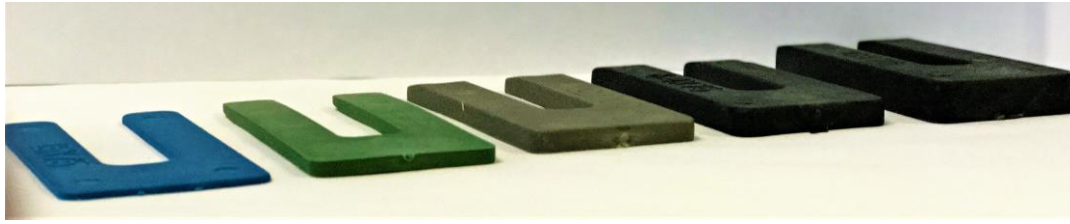

PACKERS



Part No	Description		Pack Qty
PACKER157537	1.5 x 75 x 37mm		200
PACKER327537	3.2 x 75 x 37mm		200
PACKER507537	5.0 x 75 x 37mm		200
PACKER647537	6.4 x 75 x 37mm		100
PACKER107537	10 x 75 x 37mm		100

SHIMPACK1100150	SHIM PACKERS 1.0MM X 100MM X 150MM	50
SHIMPACK2100150	SHIM PACKERS 2.0MM X 100MM X 150MM	75
SHIMPACK3100150	SHIM PACKERS 3.0MM X 100MM X 150MM	20
SHIMPACK5100150	SHIM PACKERS 5.0MM X 100MM X 150MM	10
SHIMPAC10100150	SHIM PACKERS 10.0MM X 100MM X 150MM	5



HARDWARE PRODUCTS FENCE GUTTER & FACIA TOUCH UP PAINT

Galmet Fence, Gutter, Fascia (FGF) is a durable exterior acrylic spraypaint specifically designed for touching up scratched or damaged Colorbond® steel surfaces.

Available in a range of Colorbond® colours.

Size: 350gm Aerosol



OTHER GALMET PRODUCTS

CODE	COLOUR	AEROSOL SIZE
SPRAY PAINT		
SPFB	Flat Black	350gm
SPSI	Silver	350gm
SPSR	Signal Red	350gm
SPWH	White	350gm
ANTI CORROSIVE PRIMERS		
SPEP	Keytite Etch Primer	350gm
PROTECTIVE COATINGS		
SPD	Duragal	350gm
RUST PREVENTATIVE		
SPCOLD	Cold Galvanizing	400gm
Dy-Mark Zinc Guard Cold Galvanising Coating		
SPCOLDDYMARK		400gm



It is designed to etch and bond to ferrous and non-ferrous metals.

Galmet® Duragal® is quick drying, bright silver coloured aluminium rich paint which provides the appearance of new DuraGal® Steel or hot-dip galvanized surface. The high aluminium content provides corrosion protection by creating a superior barrier to moisture & other corrosive agents compared to conventional bright silver paints.

It is an organic rich zinc coating with approximately 92% zinc in dry film. Provides long term protection to iron and steel.



HAND TOOLS

WISS SNIPS - METALMASTER SNIPS

- Non-slip serrated jaws of Wiss Metalmaster Snips are made of extra tough wear resistant molybdenum steel.
- Jaws provide extra service demanded by the compound lever action.
- Wiss Snips withstand the severe strain of cutting heavy stock and tight curves.
- Jaws have self-opening action for fast, effortless feed.
- Handles formed from high strength steel.
- Grips are non-slip and textured for superior control, safety and comfort.
- Convenient protective safety latch. • Handles with handy hang-up holes.
- Favorite tool of metal-working craftsmen. • Cutting capacity 18 gauge (1.2mm)



CODE	DESCRIPTION
M1R	Cuts Left Red Grips
M2R	Cuts Right Green Grips
M3R	Cuts Straight Yellow Grips

MULTIMASTER SNIPS PRICE

Compound action, 3" long blade for making long cuts in a wide range of materials
Cuts up to 20 guage low carbon cold rolled steel.



M300 Cuts Straight, Left & Right Orange Grips

SPARE WISS SNIP SPRINGS

P406	SUITS M1R/3R/5R/6R
P407	SUITS M2R/7R

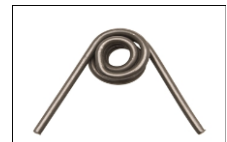

SPARE WISS SNIP SPRINGS

WLP	Leather pouch suitable for Wiss Snips
-----	---------------------------------------



WISS HAND SEAMERS

WS3	3" Hand Seamer Straight
WS6	6" Hand Seamer Straight
WC5S	HAND CRIMPER 5-BLADE 1-1/4" THROAT DEPTHG



WS3



WS6



WC5S



HAND TOOLS

MIDWEST SNIPS



MIDWEST SNIPS - OFF-SET SNIPS

Off-set models in three patterns keep user's hand above material being cut and flow material away from blades for ease of cut. They have the capacity of cutting 18 gauge cold-rolled sheet metal and 22 gauge stainless steel metal.

- P6510L** Cuts Left Red Grips
- P6510R** Cuts Right Green Grips
- P6510S** Cuts Right straight Grips

part number	picture	cutting length / capacity
MWP6510-L		1-1/4" (31.8mm)
MWP6510-S		1-1/2" (38.1mm)
MWP6510-R		1-1/4" (31.8mm)



STERLING AVIATION SNIPS



CODE	DESCRIPTION
29-851	Cuts Left Red Grips
29-852	Cuts Right Green Grips
29-853	Cuts Straight Yellow Grips



STERLING BLACK PANTHER SNIPS

Sterling's Black Panther 700 series precision snips are produced to the highest levels of engineering with a total commitment to develop the most durable and refined industrial snip on the market. Ideal for all industrial applications including wire netting, light gauge aluminium, carpet, leather, Kevlar®, and many other items.

- 185mm (7") black handled snips
- Comfort grip ergonomically designed handles
- Stainless Steel serrated edge blades for increased cutting capacity
- Ideal for multiple applications from thin wire to Kevlar®
- Ideal knife replacement tool

CODE
29-701



HAND TOOLS

SCREWDRIVERS



Acetate Handled



●Standard Tip (Slot)

Code	Description
65.545	3mm x 45mm
65.542	5mm x 100mm
65.548	6mm x 200mm
65.553	10mm x 250mm



●Phillips Tip

Code	Description
65.522	#1 Phil x 100mm
65.585	#2 Phil x 200mm
65.525	#3 Phil x 150mm

Acetate Handled Insulated



●Standard Tip (Slot)

Code	Description
65.580	5mm x 150mm



●Phillips Tip

Code	Description
65.576	#2 Phil x 150mm

Screwdriver Sets

Case Acetate Screwdriver set (T186) - 14 Pce



Code	Contains
65.750	#1 Phil x 38mm #0 Phil x 60mm #1 Phil x 100mm #2 Phil x 150mm #3 Phil x 150mm #2 Phil x 200mm 6mm Slot x 38mm 3mm Slot x 45mm 4mm Slot x 75mm 5mm Slot x 100mm 6mm Slot x 150mm 6mm Slot x 38mm 8mm Slot x 200mm 10mm Slot x 250mm 5mm Slot x 150mm Insul



Radiator Hose Clamp Tool

Adjustable Wrenches - Chrome



- Strong Flexible shaft allows access to hard-to-get at positions.
- Supplied with 1/4" (6mm), 9/32"(7mm), 5/16"(8mm) sockets.

Code	Description
70679	



Code	Size
87.431	150mm
87.432	200mm
87.433	250mm
87.434	300mm

HAND TOOLS

PLIERS HIGH VOLTAGE - S SERIES 1000V

Crescent®

Pliers



●Diagonal Cutting Pliers

Code	Description
CHV5428	200mm



●Combination Pliers

Code	Description
CHV508	200mm



●Long Nose Pliers

Code	Description
CHV6548	200mm



●Multi-Grip Pliers

Code	Description
CHV410	250mm

Heavy Duty End Cutting

Wire Strippers



●End Cutting Nippers - Cushion Grip

Code	Description
72-9CVN	230mm



●Wire Strippers

Code	Description
CWS1	Cuts & Strips 24-10 AWG

Crimping Tools

Conduit Cutters



●Crimping Tools

Code	Description
Non Insulated Terminals	
CCT8	22-8AWG 0.5-10mm
Insulated Terminals	
CCT10	22-10AWG 0.5-6mm



●Conduit Cutters

Code	Description
CCC42	Cuts 3 - 42mm

HAND TOOLS

CODE	Overall Length mm	Jaw Capacity
CURVED JAW WITH WIRE CUTTER		
C7CVN	175mm	42mm
C10CVN	250mm	48mm
LONG NOSE WITH WIRE CUTTER		
C6NVN	150mm	58mm
C9NVN	230mm	73mm
C-CLAMPS SWIVEL PADS		
C6CCSVN	150mm	73mm
C11CCSVN	280mm	102mm
SHEET METAL TOOL		
C8SMVN	200mm	19mm

Crescent®



Sterling

ULTIMAX BAR CLAMPS

- Cushion tips grip firmly for added protection on soft materials
- Ergonomic nylon handles with ribbed design for extra grip
- Induction hardened steel rail ensures longer life
- Quick conversion from clamp to spreader
- Max. clamping force: 60kg

BC60-150	150MM
BC60-300	300MM
BC60-450	450MM



Sterling

STERING ULTIMAX WOOD CHISELS

- Forged steel core with through tang design for maximum striking force
- Extra large striking cap for repetitive use at any angle
- Fully hardened blade for professional use and long life
- Split proof acetate handle for reinforced toughness
- Ergonomic over moulded grip for added comfort

CHISELWOOD19	19MM
CHISELWOOD25	25MM





HAND TOOLS RING & OPEN END SPANNERS

Spanners

Crescent®



•Metric Spanners

Code	Size
SPANNERROE7	7mm
SPANNERROE8	8mm
SPANNERROE9	9mm
SPANNERROE10	10mm
SPANNERROE11	11mm
SPANNERROE12	12mm
SPANNERROE13	13mm
SPANNERROE14	14mm
SPANNERROE15	15mm
SPANNERROE16	16mm
SPANNERROE17	17mm
SPANNERROE18	18mm
SPANNERROE19	19mm
SPANNERROE20	20mm

•A/F Spanners

Code	Size
SPANNERROE1/4	1/4"
SPANNERROE5/16	5/16"
SPANNERROE3/8	3/8"
SPANNERROE7/16	7/16"
SPANNERROE1/2	1/2"
SPANNERROE9/16	9/16"
SPANNERROE5/8	5/8"
SPANNERROE11/16	11/16"
SPANNERROE3/4	3/4"
SPANNERROE13/16	13/16"
SPANNERROE7/8	7/8"
SPANNERROE15/16	15/16"
SPANNERROE1	1"

1/2" Drive Metric Sockets

•Metric Sockets

Code	Description
SOM8	8.0MM
SOM9	9.0MM
SODIM10	10.0MM
SOM11	11.0MM
SOM12	12.0MM
SOM13	13.0MM
SOM14	14.0MM
SOM15	15.0MM
SOM16	16.0MM
SOM17	17.0MM
SOM18	18.0MM
SOM19	19.0MM
SOM20	20.0MM
SOM21	21.0MM
SOM22	22.0MM
SOM23	23.0MM
SOM24	24.0MM

STANLEY



•Deep (Long) Impact Sockets

Code	Description
SODIM10	10.0MM
SODIM11	11.0MM
SODIM12	12.0MM
SODIM13	13.0MM
SODIM14	14.0MM
SODIM15	15.0MM
SODIM16	16.0MM
SODIM17	17.0MM
SODIM18	18.0MM
SODIM19	19.0MM
SODIM20	20.0MM
SODIM21	21.0MM
SODIM22	22.0MM
SODIM23	23.0MM
SODIM24	24.0MM
SODIM25	25.0MM
SODIM26	26.0MM



Ratchets & Extensions



•Ratchet

Code	Description
CRW12	1/2" Ratchet



•Extensions

Code	Description
CDTA11	1/2" x 75mm
CDTA12	1/2" x 125mm
CDTA13	1/2" x 250mm

HAND TOOLS

HAMMERS & MALLETS

Hammers



●Fibreglass Shaft Claw Hammer

Code	Size
51.061	20oz/570g



●Ball Pein Hammer Wooden Hickory Handle

Code	Size
11435	20oz/566g



●Hammer Cross Pein

Code	Size
SJ-CPH12	12oz (340g)



●Ball Pein Hammer Wooden Hickory Handle

Code	Size
54.193	OA 405mm 32oz



●Mallet Rubber - Fibreglass Handle

Code	Size
SJ-RM24FG	24oz (680g)



●Dead Blow Hammer

Code	Size
82240	18oz Polyurethane Head
82242	33oz Polyurethane Head



●Compo-Cast® Standard Head Dead Blow Hammer

Code	OA LTH	Size
57.532	327mm	595g
57.533	362mm	1.19kg



●Wire Brush 4 Row Timber Handle

Code	Size
BRUSHWIRE	4 Row



Non-sparking soft face hammer of Uni-Cast™ construction has no exposed metal. Soft faces do not mar surfaces or equipment. Do not absorb liquids. Dead blow function uses steel shot, steel reinforced handle provides added strength and safety, resists breaking on overstrike.



●Cold Chisels

Code	OA Length	Blade Width
16.286	140mm	10mm
16.287	150mm	12mm
16.288	170mm	16mm
16.289	175mm	18mm
16.290	200mm	22mm
16.291	300mm	25mm



●Wire Scratch Brush 0.3mm Steel Wire

Code
BRUSHWIREUNIV



HAND TOOLS

Allen Keys

WRENCH HEX

●Wrench Set - Short Series Metric

1.27, 1.5, 2, 2.5, 3, 4, 5, 6, 8, 10mm

Code	Description
03020113	Red



●Wrench Set - Short Series Imperial

1/16, 5/64, 3/32, 1/8, 5/32, 3/16, 7/32,
1/4, 5/16, 3/8"

Code	Size
03019917	Green

Soldering Irons

Weller



●40 Watt / 240 Volt Electric Soldering Iron

Code	Description
SP40DAU	40Watt

●80 Watt / 240 Volt Electric Soldering Iron

Code	Size
SP80DAU	80Watt



Crescent

Crescent Cable Ties



Code	Description	Pack Qty
100mm Length		
WB4100	Black 100mm x 2.5mm	100.00
200mm Length		
WB8100	Black 200mm x 4.6mm	100.00
300mm Length		
WB12100	Black 300mm x 4.8mm	100.00
WB12100HD	Black 300mm x 7.6mm Heavy Duty	100.00
370mm Length		
WB14100	Black 370mm x 4.8mm	100.00
CT370HD	Black 370mm x 7.6mm	100.00
450mm Length		
WB18100HD	Black 450mm x 8.0mm Heavy Duty	100.00



Sterling Single Edge Razor Blades

Used in the automotive, glazing and cleaning industries, the Sterling Single Edge razor blades are the most popular general purpose scraper blade.

30-112	Pkt 100
--------	---------



UTILITY KNIVES

CODE	DESCRIPTION
68	Retractable knife with snap-off blades 18mm Sterling
201-4	Replacement blade fits all 18mm snap-off knives card of 10
412-1	Safety Knife Auto-Retract Sideslide Sterling
412B-1	Replacement blade safety knife Auto-Retract Sideslide Pkt 10
119-2D	Knife trim retract with blades fluoro green/orange
STANLEYKNIFE	Retractable Utility Stanley knife Classic 10.099
3038	Stealth Knife Autoloading Sliding
11-700	STANLEY Knife blades heavy duty Fat Max Pkt 5
11-700T	STANLEY Knife blades heavy duty Fat Max Pkt 10
11-700A	STANLEY Knife blades heavy duty Fat Max box 100
921-2D	Knife blades with dispenser Sterling Pkt 100
5192	STANLEY Concave Knife blades heavy duty 0-11-952 Pkt 5
962-4D	Sterling Deep Hook blades Trimming Pkt 5
OLFA CUTTERS 	
A	A professional cutter 9mm blade snap
L-1	Olfa's top selling snap blade cutter. For general use 18mm
XL-2	Extra long knife for extended reach 18mm blade
H-1	For extra heavy duty 25mm blade snap
LL	Heavy Duty two handed use 18mm Blade OLFA Knife
SPARE OLFA BLADES	
AB-10B	Standard snap blades 9mm Pkt 10
AB-50	Standard snap blades 9mm Pkt 50
LB-10B	Heavy duty snap blades 18mm Pkt 10
LB-50	Heavy duty snap blades 18mm Pkt 50
HB-5B	Extra heavy duty snap blades 25mm Pkt 5

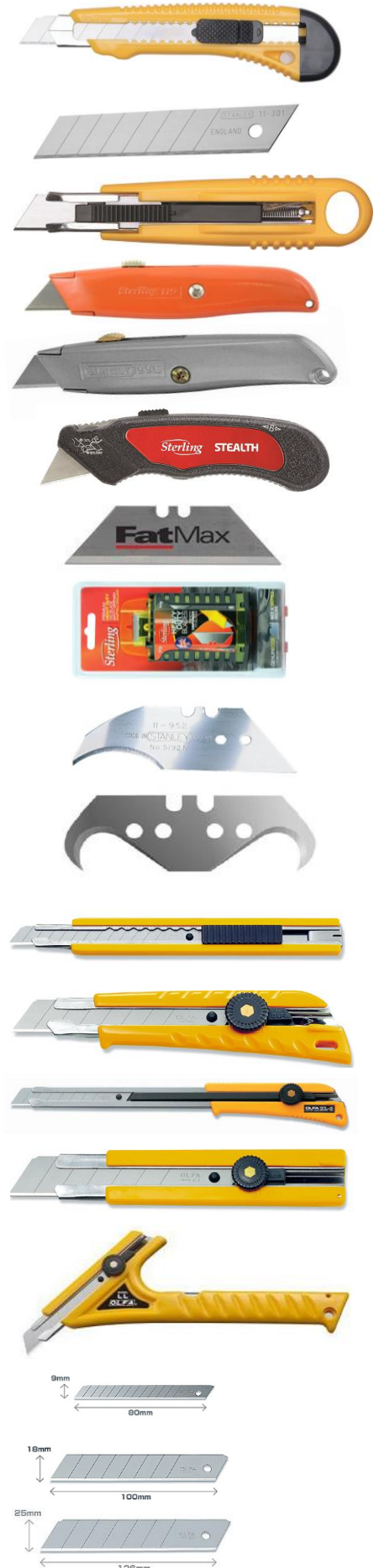

HAND TOOLS

MEASURING & MARKING

Combination Square

Lufkin

- Brass knurl nut and scribe head
- Sturdy zinc sock
- Made in U.S.A
- Metric inch graduations.
- High visibility yellow



Code: LCS12

Rules Stainless Steel

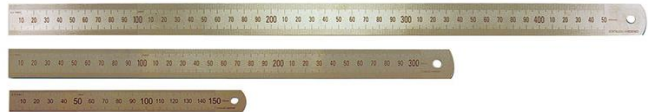

- Hardened Stainless Steel rules
- Metric/imperial markings and metric only markings available
- ISO9001 certified manufacturer assures accuracy
- All markings are etched into the Stainless Steel for durability
- Metric only rules have conversion chart on back

Code: 3021-M 300mm Metric Only

Code: 3021 300mm/12in

Folding Rules

Lufkin

- LFBSI
- Sturdy folding rule with bevelled edge
- Clear markings
- 4 Fold 1 metre

Code: LFBSI



- LFSSI
- Clear markings
- Sturdy folding rule with square edge
- 4 Fold 1 metre

Code: LFSSI



Spirit Levels - Big Boss

Lufkin

Lufkin Level with carry bag 120cm

Code: LBBL120



Chalk Lines

Lufkin

Chalk & Reel Combo 30m
LCR30M

- ABS & TPR construction for increased durability
- 3:1 Wind ratio for quick retrieval
- High grade cotton line provides clear marking & long life
- Rubber moulded areas for improved grip
- 112g chalk refill included

Code: LCR30M



Chalk Powder Refills
224g



Blue
Code: LCBL224

Red
Code: LCRD224

STANLEY

Aluminium Chalk Reel 30m
47-480L FATMAX

- Die-cast aluminium housing for durability
- 2X stronger premium polymer line
- 5:1 Gear ratio for 5X faster rewind
- Quick gear release clutch for smooth line retraction
- Stainless steel hook and crank handle for durability
- Chalk View case for viewing the chalk volume

Code: 47-480L



MEASURING TAPES

ARS Tapes



Sterling

FLURO



Code	Description		
889	8m x 25mm Metric		

Code	Description		
V8025F	8m x 25mm Metric		

ARS Tapes



Ultimax Tape



EZY-READ

- Ezy-Read Tapeline
- Each numeral on the tape is totally distinct from other numbers. This enables excellent definition & makes it easy to read.



- Manufactured in Australia

Code	Description		
TMX8025	8M X 25mm Metric		

Code	Description		
ELW148S110	8M X 25MM Metric		

Hi-Viz Tapes

Crescent



Tape Trademx
Lufkin



Hi-Viz

Code	Description		
NT410SI	10M X 25MM Metric		
NS30ME	30M/100' X 10MM Metric/English		

Code	Description		
TM48M10	8M X 25MM Metric		

FatMax® Tapes

STANLEY

FatMax® Tape

- Blade Armor™ coating is a patented industrial Thermoplastic coating. Its on the first 150mm of the FatMax™ Tape Rules for maximum durability and reduced blade breakage.
- Heavy duty Mylar Polyester film coating extends blade life up to ten times longer.
- FarMax™ tapes have a 32mm wide blade
- 3.3 metres of standout and easy to read graphics



Code	Description		
FATMAX	8M X 32MM 33-732 Metric		
FATMAX10M	10M X 32MM 33-829 Metric		

- Fibreglass open frame

Code	Description		
OF3013	30M X 13MM Metric		

ADHESIVES

Bonding

LOCTITE

Instant Adhesive - Loctite 401

- Low viscosity and fast curing cyanoacrylate adhesive
- Can be used with PP primer 770 for polyolefin bonding
- Less dependant on surface moisture for cure speed than other standard CA grades.
- Temperature range: -55°C to +80°C
- Particularly suited for bonding a wide range of materials including metals, plastics and elastomers.

Code: 40124-25



Instant Adhesive - Loctite 406

- High strength and low viscosity cyanoacrylate
- Fast fixing time of 2 to 30 seconds
- Can be used with PP primer 770 for polyolefin bonding
- Temperature range: -55°C to +80°C
- General purpose adhesive for difficult top bond surfaces. Bonds Santoprene rubbers.

Code: 40633-25



Threadlocking LOCTITE



Loctite 222

- Low Strength

Code: 22250



Loctite 243

- Medium Strength

Code: 22250



Loctite 263

- High Strength

Code: 22250

Super Glue



- ◆ Superior adhesion
- ◆ Instant bonding
- ◆ Bond most materials
- ◆ No drip formulation
- ◆ A range of pack options including strip 12 pack

SUPER GLUE V-TECH 3gm

Code: VT112V



Bonding of metal, timber, plastic, ceramic, glass & fiberglass.
Excellent resistance to most chemicals

- ◆ Clear in colour
- ◆ Rapid set
- ◆ High strength
- ◆ 2 part formula

EPOXY GLUE RAPID 3 TON 4MIN V-TECH 25ML

Code: VT146

TAPES

Electrical Insulating Tape

- Black 18mm x 20mtrs



Code	Description
2110	Black

PVC Duct Tape - Nitto

- Black 48mm x 30mtrs
- Grey 48mm x 30mtrs



Code	Description
DUCTTAPEB	Black
DUCTTAPEG	Grey

Gaffer Tape 357

- Grey 48mm x 40mtrs



Code	Description
GAFFER	Grey

Masking Tape

- 24mm x 50mtrs
- 48mm x 50mtrs



Code	Description
MASKTAPE24	
MASKTAPE48	

Stylus 973 Reinforced Aluminium Foil

- Tape 48mm x 50mtrs
- Tape 72mm x 50mtrs



Code	Description
FOILTAPE48	48mmx50mtrs
FOILTAPE72	72mmx50mtrs

Stylus 740 Tissue Tape Double Sided

- Hi-tack acrylic adhesive
- 24m x 33mtrs
- 48m x 33mtrs



Code	Description
5238	12mm x 33mtrs
5242	24mm x 33mtrs
5246	48mm x 33mtrs

PACKING TAPE 0903 101 NACHI TRANS

- Tape 48mm x 75mtrs



Code
TAPEPACK4875

STRETCH FILM ROLL

- 500mm x 380mtrs x 25UM



Code
STRETCHFILM

TAPE 370 GENERAL PURPOSE CLOTH YELLOW

- Tape 48mm x 25mtrs



Code
2591

MASKING TAPE YELLOW JOYNA 223

- Tape 48mm x 50mtrs



Code
MASKTAPEY48

TAPES

3M™ VHB™ Tape 4991 Grey

- Grey 12mm x 3.0mm x 33mtrs

3M VHB Acrylic Foam Tape is a double coated 2.3mm pressure sensitive adhesive tape for bonding many painted metals, as well as unpainted metals, and higher surface energy plastics. 3B VHB Acrylic Foam Tape 4991 is appropriate for applications which demand a thicker conformable products.



Code	Description
DST12VHB4991	Grey

Body Mould Tape 2830

- 12mm x 61mtrs

This is an automotive specific tape ideal for attaching vehicle body side mouldings, trim and emblems. Strong bonding and easy to use simply cut the tape to size leaving no mess. Very high strength double sided adhesive.



Code	Description
AT235431	Body Mould Tape

Engineers Chalk - Large Stick

- Economical and semi-permanent marking
- Ideal for industrial grade applications
- Quick and easy to layout jobs



Code	Description	Box Qty
ENGCHALK	80x10x10mm	50

Split Cotter Pins - Steel Z/P

Code	Size	Box Qty
CP216	M2.0 X 16	200
CP2525	M2.5 X 25	200
CP2532	M2.5 X 32	200
CP3220	M3.2 X 20	200
CP3225	M3.2 X 25	200
CP3232	M3.2 X 32	200
CP3236	M3.2 X 36	200
CP3250	M3.2 X 50	200
CP3256	M3.2 X 56	200
CP420	M4.0 X 20	200
CP436	M4.0 X 36	200
CP440	M4.0 X 40	200
CP450	M4.0 X 50	200
CP463	M4.0 X 63	200
CP532	M5.0 X 32	200
CP556	M5.0 X 56	200
CP571	M5.0 X 71	200
CP580	M5.0 X 80	200



LUBRICANTS & PENETRANTS



CRC 5.56

400g Aerosol

CRC 5-56 is a multi purpose lubricant that has superior penetrating power that breaks through rust and corrosion while it cleans away scale and dirt. Eliminates the need for many disassembly operations. Protects metals against corrosion and displaces moisture to help start wet engines.



Code: CRC5.56

CRC 808 Silicone Spray

330g Aerosol

CRC 808 Silicone Spray is a concentrated formula that provides a thin, durable, odourless film that revives, lubricates, waterproofs and protects. It will not mark or stain and is ideal for use on all metal, plastic, rubber fabric, wood and painted surfaces. CRC 808 Silicone spray lubricates door locks, hinges, linkages, window guides and brushes. It reduces friction and galling even on metal surfaces. Ideal for in-plant conveyors, guides and rails, mould release, rolling and sliding mechanisms.



Code: CRC808

CRC 2.26

450g Aerosol

Improves electrical properties. CRC 2.26 displaces and seals out moisture, prevents corrosion, cleans, lubricate and penetrates. CRC 2.26 is a stable, inert organic formula, especially prepared to prevent and repair electrical failures due to moisture, corrosion, dirt or friction.



Code: CRC226

CRC Electrical Quality Silicone

300g Aerosol

CRC Electrical Quality Silicone is a high-quality multi-purpose formula that lubricates, waterproofs and protects with a thin clear film that is non corrosive and non staining. It has a low surface tension which permits better coverage and deeper penetration. It has superior lubricity for metal to non-metal surfaces and is non hardening to help eliminate corrosion.



Code: CRC2094

INOX All Purpose Lubricant

300g Aerosol

- Displaces, Penetrates Lubricates & Protects
- Contains No silicon, acid, kerosene or dieselene
- Will not harm metal points or surfaces, plastic, paints, enamels, fibreglass, formica or neoprene seals.
- Doesn't dryout, gum up, become goeey or sticky.
- Doesn't wash off with water!
- Non-conductive, non-static, non-toxic, non-corrosive Non-staining.



Code: INOX

WD-40

425g Aerosol

- Stop squeaks.
- Drives out moisture.
- Cleans and protects.
- Loosens rusted parts.
- Frees sticky mechanisms.



Code: WD40

CRC Anti-Spatter - Welding

300g Aerosol

Eliminates the need to chisel, grind or wire brush after welding. Water based formula allows easy clean up without the use of solvent cleaners. Prevents spatter from adhering to surrounding metal surfaces during welding Contains no ODCs. Does not contain silicone Rust inhibiting additive prevents flash rust on on in-process and surrounding metal surfaces. Non-hazardous decomposition. Low odour



Code: CRC3033

3M 90 Hi-Strength Spray Adhesive

500g Aerosol

Ideal for mounting decorative laminates to tables, cabinets & shelving.

- High Bond Strength
- Quick Dry Time
- High Temperature Resistance



Code: ADHESIVE90

CARPENTERS PENCILS & PAINT BRUSHES

Carpenters Pencils
Medium Hard Red



Code: CP1

Lufkin Bricklayers Line



No.8 X 100M
Code: LBL100L LIME
Code: LBL100P PINK
Code: LBL100W WHITE

HAND CLEANERS

Super Grit Hand Cleaner

The combination of our popular "Waterless" hand cleaner and deep scrubbing fine polybead grains gives an added abrasive power for the removal of heavy grease and grime from the hands. Supa Grit effectively removes deeply embedded grease, oil, bitumen, paint, etc. It is ideal for use in heavy industrial applications. Contains lanolin.



Code: SG21 21kg drum

Orange Power Hand Cleaner

Orange Power Hand Cleaner with fine polybeads is a stiff hand cleaner containing lanolin and citrus oils. Orange Power removes the toughest grime, oil, paint, ink, silicones, metal stains and more. Also available in easy to use pump packs.



Code: HANDCLEANER5LTR 5L Pump Pack
Code: HANDCLEANER19KG 19kg Drum

Bags of Rags

Code: RAGS10KG Rags Coloured T Shirt 10kgs
Code: RAGSPUREWHI10KG Rags Pure White T Shirt 10kgs



PAINTBRUSHES & ROLLERS

Paintbrushes Economically Priced Brushes

Code	Description	Size
PB12	Paint Brush	12MM
PB25	Paint Brush	25MM
PB38	Paint Brush	38MM
PB50	Paint Brush	50MM
PB75	Paint Brush	75MM
PB100	Paint Brush	100MM



White Bristle range

- ◆ Wooden handle
- ◆ Economically priced
- ◆ Great for parts clean up
- ◆ Suitable for applying adhesives
- ◆ Range of sizes to suit all applications

Baby Roller

Code	Description	Size
FR75	Foam Roller	75mm

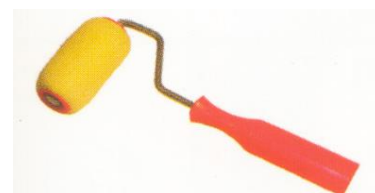

Roller Frames

Mini Slide-on Frame - Suits all 100mm roller sleeves

Code	Description	Size
12031	Mini Roller Frame	100mm

Heavy Duty Trade Roller Frames

Code	Description	Size
12029	HD Roller Frame	230mm
12030	HD Roller Frame	270mm

Roller Covers

Mini Roller Covers

Code	Description	Size
12015	Foam Cover Pk 10	100mm
12002	Fabric Cover Pk 10	100mm

Polyester Roller Covers

Code	Description	Size
737	Oldfields Rough Surfaces Long Nap 20mm	270mm
12013	Phoenix Roller Cover 10mm Nap Pack of 3	230mm
12027	Phoenix Roller Cover 10mm Nap Pack of 3	270mm
12026	Phoenix Roller Tray Kit includes 1 Roller Cover	230mm
12027	Phoenix Roller Tray Kit includes 2 Roller Covers	270mm



HINGES

Butt Hinges Steel Fixed Pin Z/P

Code	A	B	Thickness	Box Qty
91915	35	28		20
91925	50	40	1.2	20
92145	63	42	1.6	20
91935	70	50	1.6	20
91945	85	60	1.6	20
92165	89	54	1.6	20
91955	100	75	1.6	20

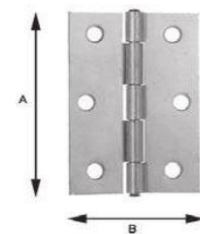

Lift Off Radius Hinge Chrome Plated

Code	A	B	Thickness	Box Qty
Right Hand				
938290	89	57	1.6	2 Per Card
Left Hand				
938290	85	60	1.6	2 Per Card

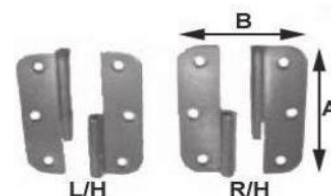

Hinges Flush (Non-Mortice) Steel Fixed Pin Z/P

Code	OA	Thickness	A	B	C	Box Qty
19115	50mm	1.2	18	12	24	20
19135	75mm	1.6	30	19	44	20
19145	89mm	1.6	30	23	53	20
Brass Plated						
19134	75mm	1.6	30	19	44	20

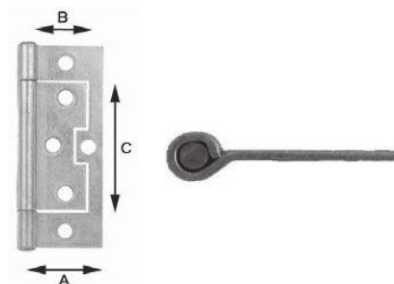

Hinges Flush (Non-Mortice) Flat Back Steel Fixed Pin Z/P

Code	OA	Thickness	A	B	C	Box Qty
19255	100mm	2.0	35	23	62	20

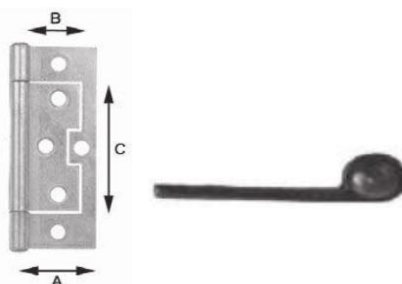

Butt Hinges Radius Steel Loose Pin

ARS Code	Finish	Size MM	Box Qty
92165Z	Z/P	89 x 57	20
92165R	BP	89 x 57	20



Butt Hinges Stainless Steel 304 Fixed Pin

Code	A	B	Thickness	Box Qty
80019	50	38	1.2	20
80129	70	50	1.6	20
80139	85	60	1.6	20

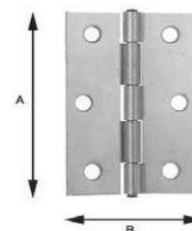

Butt Hinges Stainless Steel 304 Fixed Pin

Code	A	B	Thickness	Box Qty
82139	85	60	2	10
F.P Button Tipped Sinter-Tube Bearing				
81459	100	100	3.2	2

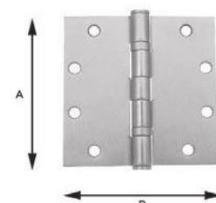

HINGES

Stainless Steel Flush Hinge Fixed Pin With Sinter - Tube Bearing Grade 304

Code	OA	Thickness	A	B	C	Box Qty
29259	100mm	2.5	41	26	52	10

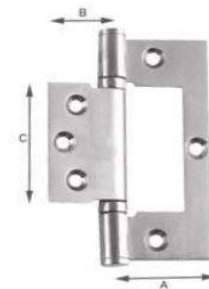

Gate Hinges Hot Dip Galv - Ball Bearing 16mm Pin Thickness - Double Butt

ARS Code	Description	Finish	Box Qty
17813	Left Hand	Gal	20
17823	Right Hand	Gal	20

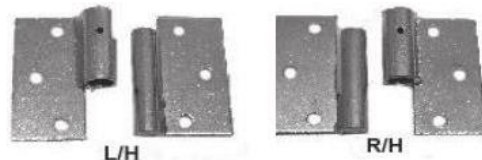

Gate Latch "D" Pattern

The D pattern gate latch is used to securely lock outdoor gates.

ARS Code	Description	Finish	Box Qty
11503	73mm Latch Length	Gal	10



Hasp & Staples - Wire Pattern Z/P

ARS Code	Description	Finish	Box Qty
HWS38	38MM 30705	Z/P	20

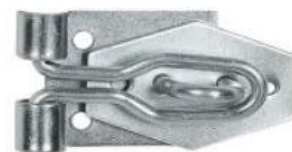

Hasp & Staples - Safety Z/P

ARS Code	Description	Finish	Box Qty
86055	100MM x 34mm	Z/P	12



Hasp & Staples - Heavy Z/P

ARS Code	Description	Finish	Box Qty
HSHD200	200mm	Z/P	10



Cabin Hook and Eye Brass

ARS Code	Description	Finish	Box Qty
879290	75mm	CP	10
879490	150mm	CP	10



Screw Eyes & Hooks

ARS Code	Description	Finish	Box Qty
70475	3.70 x 51mm	Z/P	100
70155	4.80 x 46mm	Z/P	100



70475



70155

HARDWARE

Pad Bolts Single Eye Z/P With Square Keeper

ARS Code	Description	Finish	Box Qty
PB10100	10 x 100mm	Z/P	10

Chest Handle

ARS Code	Description	Finish	Box Qty
11605	75 x 100mm	Z/P	10

Hat and Coat Hook Oval Base 75mm Chrome Plated

ARS Code	Description	Finish	Box Qty
64819	75mm	C/P	20

Hat and Coat Hook Square Base 75mm Chrome Plated

ARS Code	Description	Finish	Box Qty
64809	75mm	C/P	20

Toilet Roll Holder Steel Chrome Plated

ARS Code	Description	Finish	Box Qty
31419	Holder	C/P	10

Toilet Indicator Bolt 60mm Chrome Plated

ARS Code	Description	Finish	Box Qty
35909	60mm	C/P	EA

Passage Set Knob Brush Nickel

ARS Code	Description	Finish	Box Qty
60871	Passage Set	B/N	EA

Privacy Set Knob Brushed Nickel

ARS Code	Description	Finish	Box Qty
608910	Privacy Set	B/N	EA

Entrance Set 9KA Brushed Nickel

ARS Code	Description	Finish	Box Qty
60861	Entrance Set	B/N	EA



HARDWARE

Angle Brackets Z/P

ARS Code	Description	Finish	Box Qty
AB2222	22x22x12x1.6mm	Z/P	1000
AB3838	38x38x16x1.6mm	Z/P	1000
16155	250x250x38x6mm	Z/P	1000



Round Cushion Door Stop 75mm

ARS Code	Finish	Box Qty
DOORSTOPW	White	50
DOORSTOPG	Grey	50



RATCHET TIE DOWN ASSEMBLIES

Ratchet Tie Downs

ARS Code	Width x Length	Description	Capacity
025HCS	25mm x 5m	S HOOK	750kg
038C6S	35mm x 6m	S HOOK	750kg
025HCSHK	25mm x 5m	Hook & Keeper	750kg
070212	35mm x 6m	Hook & Keeper	750kg
050ECI	50mm x 9m	Hook & Keeper	2500kg



Replacement Straps

PWC59I	50mm x 9m	Hook & Keeper	2500kg
---------------	-----------	---------------	--------



Clip on Ratchet Winch With Strap

BCR098	50mm x 9m	Hook & Keeper	2500kg
---------------	-----------	---------------	--------



Slide on Ratchet Winch With Strap

BSR09	50mm x 9m	Hook & Keeper	2500kg
--------------	-----------	---------------	--------



HANDWARE

Code	Product description	Sizes	Pack Qty
------	---------------------	-------	----------

Maxisafe Synthetic/Coated Gloves



GNN192 GNL156 GNF124 GNP136 GGL106 GBL107 GNB126

GNN192	'Black Knight' nylon glove, nitrile coated	S - XXL	12 pairs
GNL156	'Red Knight' latex Gripmaster glove	S - XXL	12 pairs
GNF124	'White Knight' Nylon glove, nitrile foam coated	XS - XXL	12 pairs
GNP136	'Liteflex' Nylon glove, grey PU coated	XS - XXL	12 pairs
GGL106	'Green Grippa' Knitted poly cotton, green latex palm	S - XXL	12 pairs
GBL107	'Blue Grippa' Knitted poly cotton, blue latex dipped palm	S - XXL	12 pairs
GNB126	Maxisafe Blue nitrile fully coated glove, with knit wrist	M, L, XL	12 pairs

Maxisafe Cut, Heat & Needle Resistant Gloves



GKH197

GKH197	'G-Force' Cut 5 glove with HDPU palm	S - XXL	10 pairs
--------	--------------------------------------	---------	----------

Maxisafe Mechanics Gloves



GRS235 GRS255 GMA113 GMF117 GML158

GRS235	'G-Force Rigger' Synthetic Riggers Glove	S,M,L,XL,XXL	6 pairs
GRS255	'G-Force HiVis Rigger' Synthetic Riggers Glove	M,L,XL	6 pairs
GMA113	'G-Force Mechanics' Mechanics glove, full finger	S,M,L,XL	6 pairs
GMF117	'G-Force Grip' Mechanics glove, fingerless	S,M,L,XL,XXL	6 pairs
GML158	'G-Force Leather' Mechanics glove with leather palm	S,M,L,XL,XXL	6 pairs

Maxisafe Leather & Cotton Gloves



GRB140 GLC145 GKP103

GRB140	Maxisafe Natural Cowgrain Rigger Glove	S, M, L	12 pairs
GLC145	Maxisafe Candy stripe glove	XL	12 pairs
GKP103B	Maxisafe Bleached, knitted poly cotton liner	Mens, ladies	12 pairs

HANDWARE

Code	Product description	Sizes	Pack Qty	List Price
------	---------------------	-------	----------	------------

Maxisafe Welders Gloves



GWB163



GWR162



GWL164



GWB160



GWT165



GRE243

GWB163	"Blue Flame" Kevlar Welders glove	40cm	12 pairs	
GWR162	"Western Red" Kevlar welders glove	40cm	12 pairs	
GWL164	"Leftwing" Welders glove	40cm	12 pairs	
GWB160	"Black & Gold" Welders glove	40cm	12 pairs	
GWT165	Maxisafe TIG welding glove - Premium Goat Leather	10, 11	12 pairs	
GRE243	'FireForce' Extended Cuff Rigger - Premium Cow Leather	8, 10, 12	12 pairs	

Maxisafe Chemical Resistant Gloves



GPR121



GPR122

GPR121	Maxisafe Red PVC gauntlet - 27cm	One size fits all	12 pairs	
GPR122	Maxisafe Red PVC gauntlet - 45cm	One size fits all	12 pairs	

Disposable Gloves & Glove Accessories



GNB218



GLP200

GNB218	'Black Shield' Heavy Duty Nitrile, Unpowdered, Box 100	S - 2XL	1	
GLP200	Latex Disposable Gloves Powdered, Box 100	XS, S,M,L,XL	1	

EYEWARE

Code	Product description	Sizes	Pack Qty
Maxisafe Safety Glasses			



EBR330e	'Texas' Clear Safety Glasses		12 pairs	
EBR331e	'Texas' Smoke Safety Glasses		12 pairs	
ENU482	Nevada Clear Safety Glasses		12 pairs	
ENU483	Nevada Smoke Safety Glasses		12 pairs	
ENU485	Nevada Silver Mirror Safety Glasses		12 pairs	
EBR334	'SantaFe' Bronze Mirror Safety Glasses		12 pairs	
EVS300	Visispec Clear Safety Glasses		12 pairs	
ECO340	'Colorado' Clear Safety Glasses		12 pairs	
ECO341	'Colorado' Amber Safety Glasses		12 pairs	
ECO344	'Colorado' Smoke Safety Glasses		12 pairs	
ECO346	'Colorado' Blue Mirror Safety Glasses		12 pairs	
ESG456	"Maxi-Goggles" - Clear Anti-fog, Foam Bound Lens		12 pairs	
ESG485	"Maxi-Goggles" - Shade #5, Anti-fog, Foam Bound Lens		12 pairs	

Maxisafe Faceshields and Lenses



EDG440



EWH445a



01327775

EDG440	Maxisafe Oxy welding goggles		Each	
EWH445a	Maxisafe Welding helmet		Each	
01327775	Faceshield Complete Armadillo Clear		Each	
03788610	Faceshield Visor Repacement Armadillo Clear		Each	

HEADWARE

Maxisafe Safety Headwear



HVS590-W



HBS558-W

HVS590-W	Maxiguard White Vented Hard Hat, sliplock harness	N/A	Each	
HBS558	Maxisafe Hat Brim with Neck Flap - Green, Blue, White, Orange	N/A	Each	

EARWARE

Code	Product description	Sizes	Pack Qty
------	---------------------	-------	----------

Maxisafe Hearing Protection



HRE661	Class 5 Red Maxisafe 3004 Earmuff - 32dB		1 pair	
HRE662	Class 5 Blue Maxisafe 3003 Earmuff - 26dB		1 pair	
HRE664	Class 4 Green Folding Maxisafe 3007 Earmuff - 26dB		1 pair	
HRE658	Maxisafe Earmuff Hygiene Kit 3103		1 pair	
HBE635	Maxi Muff Class 5 (28dB) Earmuff		1 pair	
HQB634	QB2 Supa-Aural Quiet Band (with spare set of pads)		1	
HQB641	QB200 Replacement pads, box 50 pairs		1	
HEC644	MAXIPLUG Tapered earplug, class 5 corded, box 100 pairs		1	
HEU645	MAXIPLUG Tapered earplug, class 5, uncorded, box 200 pairs		1	
HED653	MAXIPLUG Earplug dispenser - holds 300 Pairs of earplugs		1	
HEU649	MAXIPLUG Tapered earplug, uncorded - refill bag 300 Pairs of earplugs		1	
HEU660	MAXIPLUG Tapered earplug, uncorded - trade pack of 100 Pairs of earplugs		1	
05309666	EARPLUG MAX-1 DISPOSABLE 27.0DB, uncorded pack of 200 Pairs		1	
00959072	EARPLUG MAXLITE DISPOSABLE 26.9DB LPF-1, uncorded pack of 100 Pairs		1	

BREATHWARE

Maxisafe Respiratory Protection



RES500	Maxisafe Nuisance dust respirator, box 50		1	
RES501	Maxisafe P1 respirator, box of 20		1	
RES502	Maxisafe P1 respirator with valve, box of 10		1	
RES503	Maxisafe P2 respirator, box of 20		1	
RES504	Maxisafe P2 respirator with valve box of 10		1	
RSB521	"Bandit" Assembled Half Mask with 2 Cartridges-Large		1	

BREATHWARE

Code	Product description	Sizes	Pack Qty
Professional Full & Half Face Masks & Filters		Made in Japan	



RCF01



RCA-A2



RP2R



RRS01PK

RCF01	Maxisafe Professional Twin Full Face Respirator - TPE	S,M,L	Each	
RCA-A2	A2 Gas Filter - (Dia 83mm x H35mm. Weight 68g)	N/A	Each	
RP2R	P2 Particle Filter - (Dia. 77mm x H 22mm. Weight 20g)	N/A	Each	
RRS01PK	Maxipak RS01 TPE Half Mask Respirator Painter's Kit	M,L	Each	

BODYWARE

Maxisafe Safety Vests, Disposable Wear & Knee Protection



SVV601



SVF603

COT619



KPE680 & KPS683



BB

M - Waist 83 - 94cm
L - Waist 95 - 107cm
XL - Waist 108 - 122cm

SVV601/size	Maxisafe Hi-vis yellow safety vest - day use (Class D)	M,L,XL,2XL,3XL	Each	
SVF603/size	Maxisafe Hi-vis yellow safety vest - day/night use (Class D/N)	M,L,XL,2XL,3XL	Each	
COT619	'Koolguard' White laminated disposable coveralls	M - 5XL	1	
KPE680	Gelmax Premium Gel Knee Pad		1	
KPS683	Non-marking Comfort Style knee pads		1	
BB/Size	Back Support Belt (BRACE)	M, L, XL	Each	

Maxisafe Site Safety



BTC760R

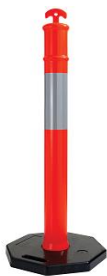

BTB758-6



BTC710



BTR713



BBF722

BTC760R	Maxisafe 450mm Reflective Traffic Cones	450mm	1	
BTB758-6	Maxisafe 6kg T-Top Bollard with base	1155mm	1	
BTC710	Maxisafe CAUTION black on yellow tape	100m x 75mm	1	
BTR713	Maxisafe Red and white barricade tape	100m x 75mm	1	
BBF722	Maxisafe Orange PVC Bunting Flagline	30 metres	1	

The logo for ARS, featuring the letters 'ARS' in a bold, white, sans-serif font. The letters are set against a dark blue oval background that has a slight 3D effect with a shadow underneath.

Why Choose ARS?

- Metro deliveries within 24 hours
- Locally stocked product
- Privately owned, family operated business with more than 20 years' experience
- Quality products, great prices, outstanding service

Australian Riveting Supplies Pty. Ltd.

51 Lakewood Boulevard
Carrum Downs Victoria 3201
Tel : (03) 9708 2743
Fax: (03) 9708 2745
Email: sales@ausriveting.com.au
Website: www.ausriveting.com.au